

COMET SYSTEM

www.cometsystem.com

Web Sensor P8510

Web Sensor P8511

Web Sensor P8541

USER GUIDE

© Copyright: COMET SYSTEM, s.r.o.

Is prohibited to copy and make any changes in this manual, without explicit agreement of company COMET SYSTEM, s.r.o. All rights reserved.

COMET SYSTEM, s.r.o. makes constant development and improvement of their products. Manufacturer reserves the right to make technical changes to the device without previous notice. Misprints reserved.

Manufacturer is not responsible for damages caused by using the device in conflict with this manual. To damages caused by using the device in conflict with this manual cannot be provide free repairs during the warranty period.

Contact the manufacturer of this device:

COMET SYSTEM, s.r.o.
Bezrucova 2901
756 61 Roznov pod Radhostem
Czech Republic
www.cometsystem.com

Revision history

This manual describes devices with latest firmware version according the table below. Older version of manual can be obtained from a technical support.

| Document version | Date of issue | Firmware version | Note |
|------------------|---------------|--------------------|--|
| IE-SNC-P85x1-09 | 2011-01-27 | 4-5-1-x | Latest revision of manual for an old generation of firmware for P85xx devices. |
| IE-SNC-P85x1-13 | 2014-02-07 | 4-5-5-x 4-5-6-0 | Initial revision of manual for new generation of P85xx firmware. |
| IE-SNC-P85x1-14 | 2015-06-30 | 4-5-7-0 | |
| IE-SNC-P85x1-16 | 2017-01-11 | 4-5-8-0 | |
| IE-SNC-P85x1-17 | 2017-10-26 | 4-5-8-1 | |

Table of contents

| | |
|--|----|
| Introduction..... | 4 |
| General safety rules | 4 |
| Device description and important notices..... | 5 |
| Getting started..... | 6 |
| What is needed for operation | 6 |
| Mounting the device..... | 6 |
| Device settings | 8 |
| Checking functions..... | 10 |
| Device setup | 11 |
| Setup using web interface..... | 11 |
| Setup using TSensor software | 18 |
| Factory defaults..... | 19 |
| Communication protocols | 21 |
| Website..... | 21 |
| SMTP – sending e-mails..... | 21 |
| SNMP | 22 |
| Modbus TCP..... | 23 |
| SOAP..... | 25 |
| Syslog..... | 26 |
| SNTP..... | 26 |
| Software development kit..... | 26 |
| Troubleshooting..... | 27 |
| I forgot the device IP address..... | 27 |
| I cannot connect to the device | 27 |
| Error or n/a is displayed instead the measured value | 28 |
| I forgot the password for setup..... | 28 |
| Factory defaults..... | 29 |
| Technical specifications | 30 |
| Dimensions..... | 30 |
| Basic parameters | 31 |
| Operating terms | 33 |
| End of operation | 34 |
| Technical support and service | 34 |
| Preventive maintenance..... | 34 |
| Optional accessories..... | 35 |

Introduction

This chapter provides basic information about device. Before starting please read this manual carefully.

Thermometer Web Sensor P8510 or Web Sensor P8511 and Web Sensor P8541 are used to measure temperature or relative humidity. Temperature can be displayed in °C or °F. Relative humidity have unit %RH. Communication with the device is realized via Ethernet network.

Thermometer Web Sensor P8510 has compact design and measures the temperature in place of installation. Web Sensor P8511 is designed to connect one probe. To Web Sensor P8541 is possible connect up to four probes. Temperature or humidity probes are available as optional accessories.

General safety rules

The following summary is used to reduce the risk of injury or damage the device. To prevent injury, please follow instructions in this manual.



The device can be services only by a qualified person. The device contains no serviceable parts inside.

Don't use the device, if it doesn't work correctly. If you think, that the device is not working correctly, let check it by qualified service person.

It's forbidden to use the device without the cover. Inside the device can be a dangerous voltage and may be risk of electric shock.

Use only the appropriate power supply adapter according to manufacturer specifications and approved according to relevant standards. Make sure, that the adapter does not have damaged cables or covers.

Connect the device only to network parts approved according to relevant standards.

Connect and disconnect the device properly. Don't connect or disconnect Ethernet cable or probes if the device is powered.

The device may be installed only in prescribed areas. Never expose the device to higher or lower temperatures than is allowed. The device has not improved resistance to moisture. Protect it from dripping or splashing water and do not use at areas with condensation.

Don't use device in potentially explosive environments. Don't stress the device mechanically.

Device description and important notices

This chapter contains information about basic features. Also there are important notices concerning to functional safety.

Values from the device can be read using an Ethernet connection. The following formats are supported:

- Web pages
- Current values in XML and JSON format
- Modbus TCP protocol
- SNMPv1 protocol
- SOAP protocol

The device can also be used to check measured values and if the limit is exceeded, device sends warning messages. Possible ways to sending warning messages:

- Sending e-mails up to 3 e-mail addresses
- Sending SNMP traps up to 3 configurable IP addresses
- Displaying the alarm status on web page
- Sending messages to Syslog server

The device setup can be made by the TSensor software or web interface. TSensor software can be free downloaded from the manufacturer's website. Latest firmware can be obtained from the technical support. Do not upload to your device firmware which is not designed for it. Unsupported firmware can damage your device.

Device does not support powering over Ethernet cable (PoE). PoE splitter must be used. Compatible PoE splitter can be purchased as optional accessories. Splitter must have 5V output with approximately 1W.



Reliability of warning messages delivering (e-mail, trap, syslog), depends on actual availability of necessary network services. The device should not be used for critical applications, where malfunction could cause to injury or loss of human life. For highly reliable systems, redundancy is essential. For more information please see standard IEC 61508 and IEC 61511.



Never connect the device directly to the Internet. If it is necessary connect the device to the Internet, properly configured firewall must be used. Firewall can be partially replaced with the NAT.

Getting started

Here you can find information necessary to put newly purchased equipment to operation. This procedure is only informative.

What is needed for operation

To install the unit you need to the following equipment. Before installation check if it's available.

- Web Sensor P8510 or Web Sensor P8511, P8541
- power supply adapter 5V/250mA (or compatible PoE splitter)
- RJ45 LAN connection with appropriate cable
- free IP address in your network
- for Web Sensor P8511 one probe. For Web Sensor P8541 up to 4 temperatures probes type DSTR162/C, DSTGL40/C, DSTG8/C or relative humidity probe DSRH

Mounting the device

- check if the equipment from previous chapter are available
- install the latest version of TSensor software. This software is used to all device settings. TSensor software can be free downloaded from the manufacturer's website. Software can be also supplied on CD. Device configuration can be made using web interface. For web configuration is not TSensor software necessary.
- contact your network administrator to obtain following information for the connection to the network:

| | |
|----------------|-------|
| IP address: | _____ |
| Gateway: | _____ |
| DNS server IP: | _____ |
| Netmask: | _____ |

- check if there is no IP address conflict when you connect the device into network for the first time. The device has from factory set the IP address to **192.168.1.213**. This address must be changed according to information from the previous step. When you installing several new devices, connect them to the network one after another.
- connect probes to Web Sensor P8511 or Web Sensor P8541
- connect the Ethernet connector
- connect the power adapter 5V/250mA
- LEDs on LAN connector should blink after connecting the power

Web Sensor P8510 connection:

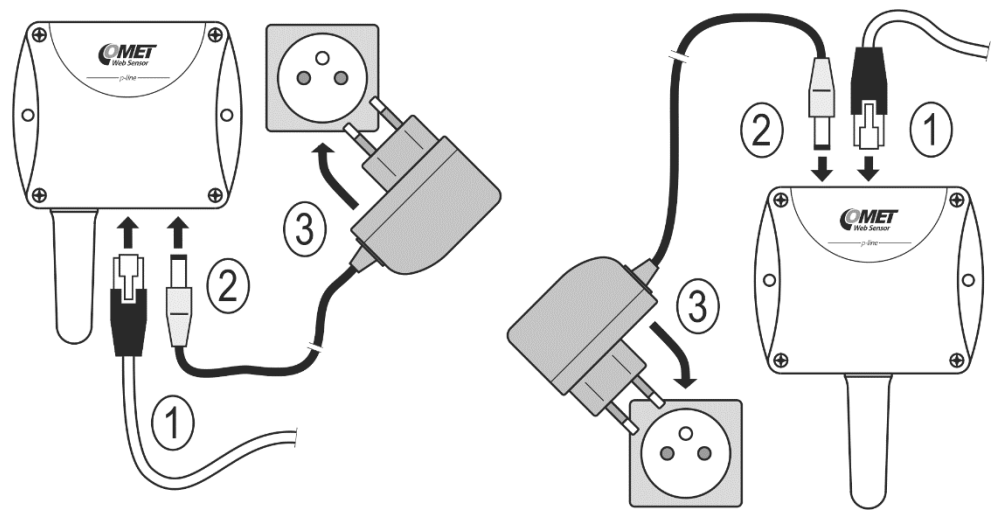

Web Sensor P8511 connection:

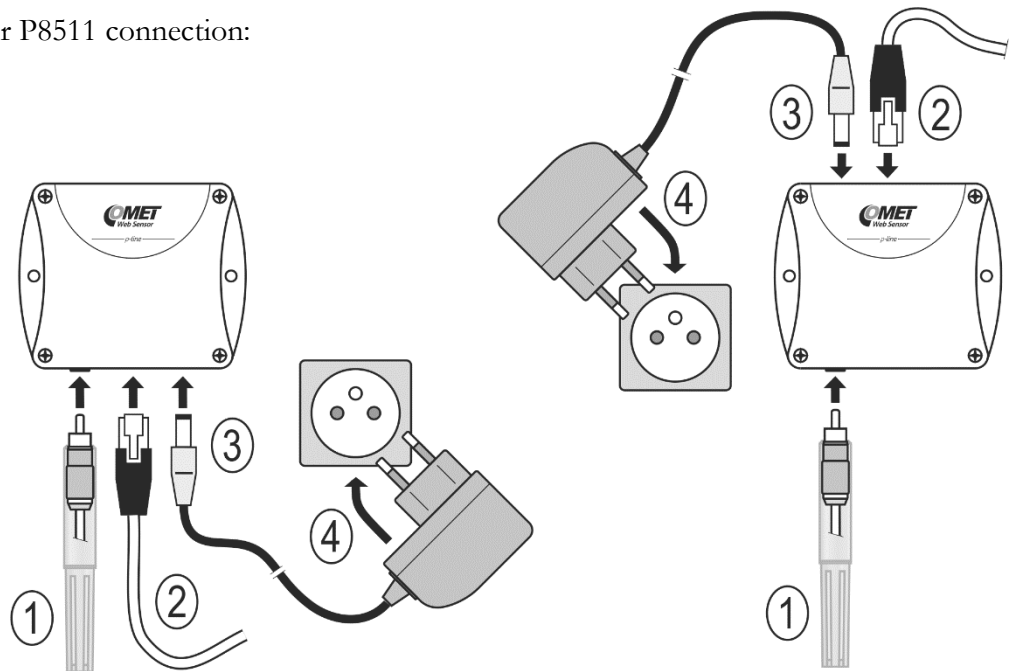

Web Sensor P8541 connection:

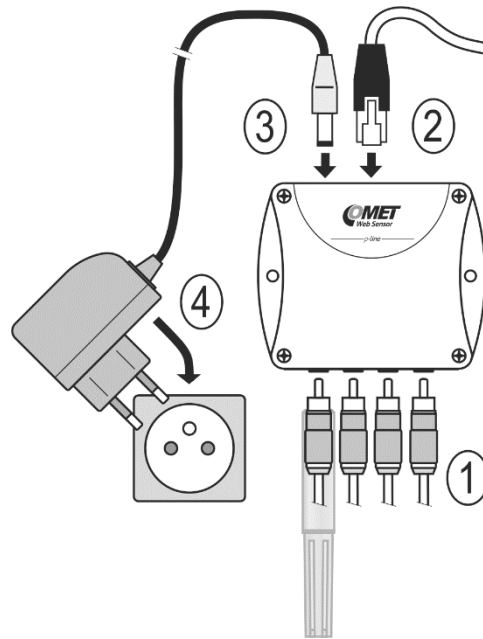

Connect via PoE splitter:

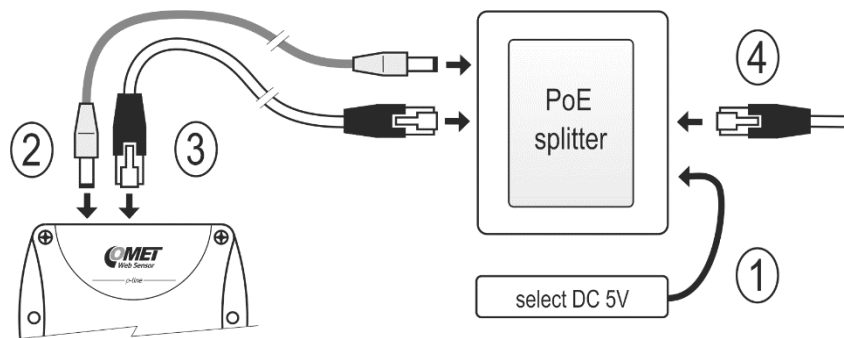

Device settings

- run configuration software TSensor on your PC
- switch to an **Ethernet** communication interface
- press button **Find device...**

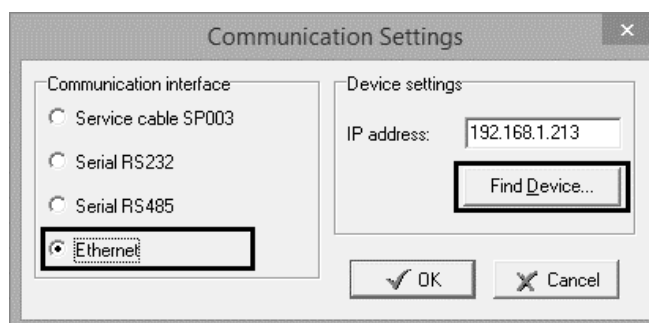

- the window shows all available devices on your network

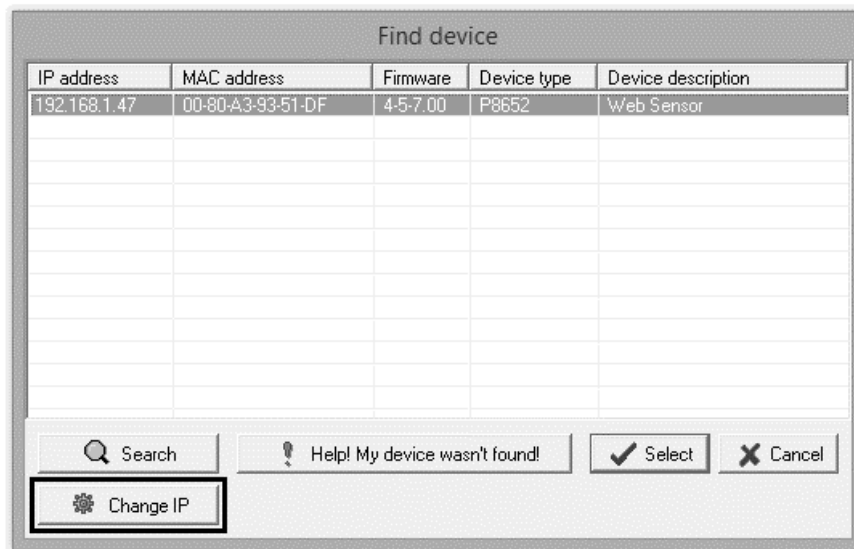

- click to **Change IP address** to set new address according to network administrator instructions. If your device is not listed, then click **Help! My device wasn't found!** Then follow the instructions. MAC address is on product label. The device is factory set to IP **192.168.1.213**.

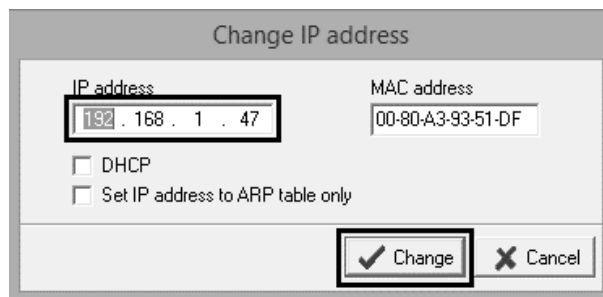

- gateway may not be entered if you want to use the device only in local network. If you set the same IP address which is already used, the device will not work correctly and there will be collisions on the network. If the device detects a collision of IP address, then reboot is performed automatically.
- after changing IP address device is restarted and new IP address is assigned. Restart of the device takes about 10 seconds.
- connect to device using TSensor software and check the measured values. If Web Sensor P8511 or Web Sensor P8541 values are not displayed, it's necessary to find probes using button **Search probes (Find probes)**.
- set the other parameters (alarm limits, SMTP server, etc.). Settings are saved after click on button **Save changes**.

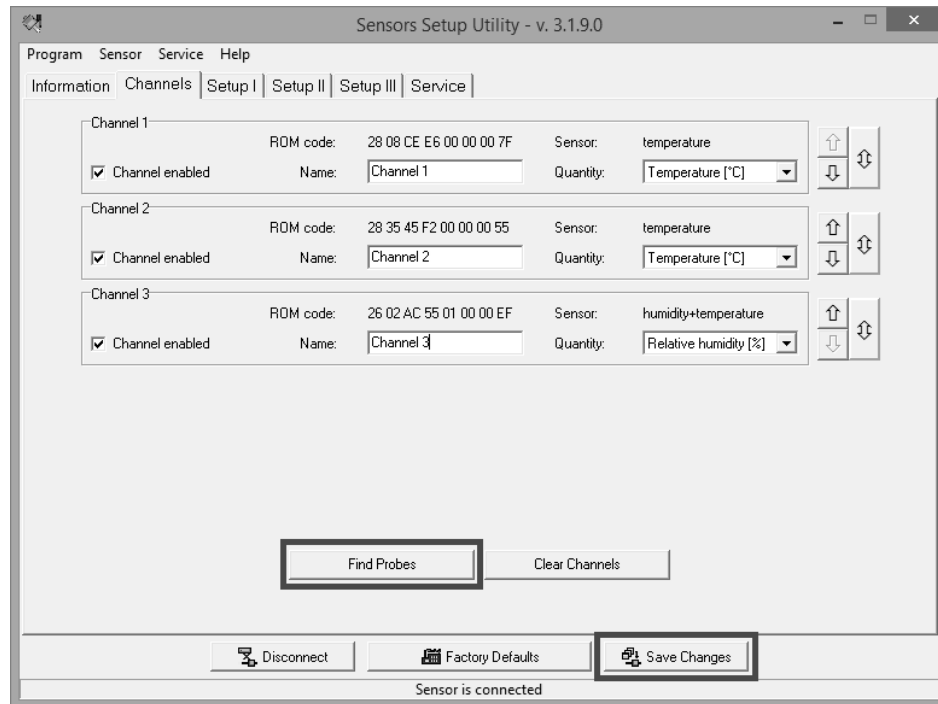

Checking functions

The last step is to check measured values on the device website. Enter the device IP address into address bar of the web browser. If the default IP address was not changed, then insert **http://192.168.1.213**.

Displayed web page lists actual measured values. If the web pages are disabled, you can see text **Access denied**. If the measured value exceeds the measurement range or probe is not correctly installed, then is shown **Error** message. If the channel is switched off, the web site displayed **n/a** instead of the value.

Device setup

This chapter describes basic device configuration. There is a description of settings using web interface.

Setup using web interface

Device can be setup using web interface or TSensor software. Web interface can be managed by the web browser. Main page will be shown when you insert device address into address bar of your web browser. There you find actual measured values. Page with history graphs is shown when you click to tile with actual values. Access to device setup is possible via tile **Settings**.

The screenshot shows a web browser window with the address bar containing '192.168.213'. The page title is 'Web Sensor' and the URL is '192.168.213'. The page displays sensor data for four channels and a navigation menu.

| Channel 1 | Channel 2 | | History .CSV dot file | Events .CSV dot file |
|---|---|--|-------------------------------|------------------------------|
| 34.1%RH alarm none min: 25.3%RH max: 34.7%RH | 32.9%RH alarm none min: 25.3%RH max: 33.7%RH | | History .CSV comma file | Events .CSV comma file |
| Channel 3 | Channel 4 | | MinMax mem | Mobile web |
| 26.1°C alarm none min: 19.6°C max: 27.6°C | 33.4%RH alarm none min: 27.3%RH max: 33.9%RH | | Events viewer | |
| | | | Settings * | About ? |

Copyright © 2015, Comet system s.r.o. All rights reserved.

General

Device name can be changed using item **Device name**. Measured values are stored into memory according **History storage interval** field. After changing of this interval all history values will be cleared. Changes must be confirmed by **Apply settings** button.

The screenshot shows the 'Settings' menu with 'General' selected. The 'General' section is active, displaying the following fields:

- Device name:** Web Sensor
- History storage interval:** 1 Min

Buttons for 'Apply settings' and 'Cancel changes' are visible at the bottom right. The left sidebar contains links for 'Back', 'General', 'Network', 'Backup', and 'Maintenance'.

Network

Network parameters can be obtained automatically from DHCP server using option **Obtain an IP address automatically**. Static IP address is configurable via field **IP address**. It is not necessary to setup **Default gateway** while you use the device inside one subnet only. **DNS server IP** is required to set for proper function of DNS. Option **Standard subnet mask** sets network mask automatically according to A, B, or C network class. **Subnet mask** field must be set manually, when network with non-standard range is used. **Periodic restart interval** enables to restart the device after the selected time since device start.

The screenshot shows the 'Settings' menu with 'Network' selected. The 'Network' section is active, displaying the following fields:

- Obtain an IP address automatically:**
- IP address:** 192.168.1.213
- Default gateway:** 192.168.1.1
- DNS server IP:** 192.168.1.1
- Standard subnet mask:**
- Subnet mask:** 255.255.255.0
- Periodic restart interval:** Off

Buttons for 'Apply settings' and 'Cancel changes' are visible at the bottom right. The left sidebar contains links for 'Back', 'General', 'Network', 'Alarm limits', 'Backup', and 'Maintenance'.

Alarm limits

For each measurement channel is possible to set upper and lower limits, time-delay for alarm activation and hysteresis for alarm clearing.

Back
Exit to main menu

General
General device settings

Network
Basic settings of the network interface

Alarm limits
Configuration of the alarm limits

Channels
General settings of the channels

Backup
Save or restore configuration

Maintenance
Factory defaults, info, etc.

Settings Alarm limits

Configuration of the alarm limits. The safe range is between high and low limit. Alarm condition occurs while measured value is out of the safe range for selected time delay. Alarm is cleared if measured value returns to safe range with hysteresis.

Channel 1 limits
Channel name: Channel 1
Current value: 24.6 °C
User adjustment: no

| High limit [°C] | Low limit [°C] | Hysteresis [°C] | Time delay [sec] |
|-----------------|----------------|-----------------|------------------|
| 50.0 | 0.0 | 1.0 | 30 |

Channel 2 limits
Channel name: Channel 2
Current value: 47.4 %RH
User adjustment: no

| High limit [%RH] | Low limit [%RH] | Hysteresis [%RH] | Time delay [sec] |
|------------------|-----------------|------------------|------------------|
| 50.0 | 0.0 | 1.0 | 30 |

Apply settings
Cancel changes

Example of setting the limit to the upper alarm limit:

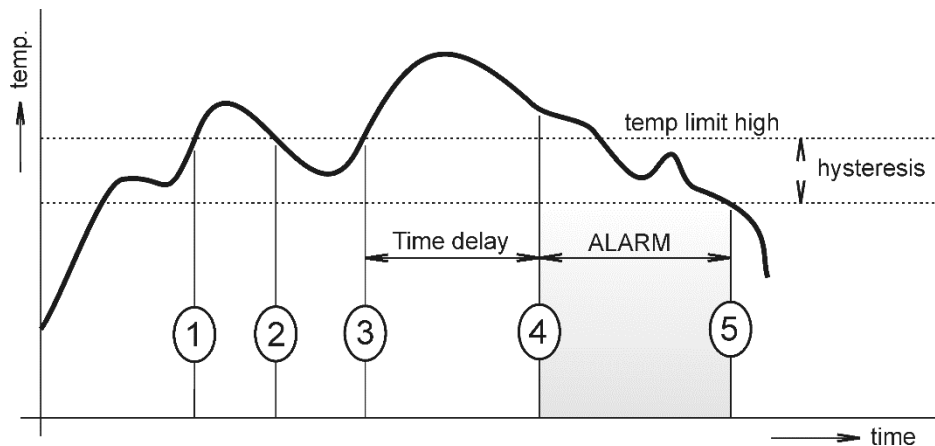

In Point 1 the temperature exceeded the limit. From this time, the time-delay is counting. Because at point 2 the temperature dropped below the limit value before the time delay expired, alarm was not set.

In Point 3 the temperature has risen over limit again. During the time-delay the value does not drop below the set limit, and therefore was in Point 4 caused alarm. At this moment were sent e-mails, traps and set alarm flag on website, SNMP and Modbus.

The alarm lasted up to Point 5, when the temperature dropped below the set hysteresis (temperature limit – hysteresis). At this moment was active alarm cleared and e-mail send.

When alarm occurs, alarm messages will be sent. In case of power failure or device reset (e.g. changing the configuration) will new alarm state evaluated and new alarm messages will be send.

Channels

Channel can be enabled or disabled for measuring using item **Enabled**. Channel can be renamed (max. 14 characters) and it is possible select unit of measured value according connected probe type. When channel is not used, it is possible copy to it one of other channels – option **Clone channel**. This option is not available at fully occupied device. **Find sensors** button starts searching for connected probes. All changes must be confirmed using **Apply settings** button. History values are cleared after changing of channel settings.

Settings Channels

General settings of the channels. Find sensors button starts search for connected probes. Connected probes can be cloned to unused channels. To change order of ROM codes Drag and Drop feature can be used. History values of the channel will be cleared immediately after changing channel settings.

Channel 1
ROM code: 28 F3 AE 56 07 00 00 0F
Sensor: temperature probe

Enabled Channel 1 temperature [°C]

Channel 2
ROM code: 26 98 B5 FA 01 00 00 2D
Sensor: humidity+temperature probe

Enabled Channel 2 humidity [%RH]

Apply settings Find sensors Clear channels Cancel changes

SOAP protocol

SOAP protocol can be enabled by option **SOAP protocol enabled**. Destination SOAP server can be set via **SOAP server address**. For setup of server port can be used option **SOAP server port**. Device sends SOAP message according selected **Sending interval**. Option Send **SOAP message when alarm occurs** sends message when an alarm on channel occurs or alarm is cleared. These SOAP messages are sent asynchronously to selected interval.

Settings SOAP

Setup SOAP protocol for database system. Current measured values are sent as XML files. For more information please read the user guide for database system.

SOAP protocol enabled

SOAP server address http://192.168.1.132/soap

SOAP server port 80

Sending interval 20 Sec

Send SOAP message when alarm occurs

Apply settings Cancel changes

Email

Email sending enabled option allows email features. It is necessary set address of the SMTP server into **SMTP server address** field. Domain name for SMTP server can be used. Default port of the SMTP server can be changed using item **SMTP server port**. SMTP authentication can be enabled using **SMTP authentication** option. When authentication is enabled **Username** and **Password** must be set.

For successfully email sending it is necessary insert **Email sender address**. This address is usually same as username of the SMTP authentication. Into fields **Recipient 1** to **Recipient 3** it is possible set address of email recipients. Option **Short email** enable sending emails in short format. This format is usable when you need to forward emails into SMS messages.

When option **Alarm email repeat sending interval** is enabled and there is active alarm on channel, then emails with actual values are sent repeatedly. **Info email sending interval** option enables sending emails at selected time interval. CSV history file can be sent together with the repeat/info emails. This feature can be enabled by **Alarm and Info emails attachment** option.

It is possible to test email function using button **Apply and test**. This button save a new settings and send a testing email immediately.

Back
Exit to main menu

Settings Email

General
General device settings

Network
Basic settings of the network interface

Alarm limits
Configuration of the alarm limits

Channels
General settings of the channels

SOAP protocol
Setup SOAP protocol for database system

Email
Alarm emails configuration

Protocols
Syslog and ModbusTCP protocol settings

SNMP
SNMPv1 protocol and SNMP Traps

Time
Synchronization with NTP server

WWW and Security
Web server and Security configuration

MinMax memory
Timestamps, clear memory

Backup
Save or restore configuration

Maintenance
Factory defaults, info, etc.

Configuration of the alarm emails. Device can send warning email when alarm on measured channel occurs. Email is also sent when alarm condition is cleared.

Email sending enabled

SMTP server configuration
For proper email sending it is necessary to setup connection to your SMTP server. SMTP authentication can be used if needed. For information about SMTP server settings please contact your network administrator or ISP.

SMTP server address

SMTP server port

SMTP authentication

Username

Password

Email configuration
Setup up to three address for email recipients. Sender address is usually the same as the username of the SMTP authentication.

Email sender address

Recipient 1

Recipient 2

Recipient 3

Short email

Alarm email repeat sending interval

Info email sending interval

Alarm and Info emails attachment

Modbus a Syslog protocols

ModbusTCP and Syslog protocol settings are configurable via menu **Protocols**. Modbus server is enabled by default. Deactivation is possible via **Modbus server enabled** option. Modbus port can be changed via **Modbus port** field. Syslog protocol can be enabled using item **Syslog enabled**. Syslog messages are sent to IP address of the Syslog server - field **Syslog server IP address**.

Back
Exit to main menu

Settings Protocols

General
General device settings

Email
Alarm emails configuration

Protocols
Syslog and ModbusTCP protocol settings

SNMP
SNMPv1 protocol and SNMP Traps

ModbusTCP protocol
Configuration of the ModbusTCP protocol. Current measured values can be read using ModbusTCP protocol. Modbus registers are described inside the user manual.

Modbus server enabled

Modbus port

Syslog protocol
Configuration of the Syslog protocol. Alarm messages can be sent to the Syslog server using UDP protocol.

Syslog enabled

Syslog server IP address

Apply settings Cancel changes

SNMP

For reading values via SNMP it is necessary to know password - **SNMP read community**. SNMP Trap can be delivered up to three IP address - **IP address of the Trap recipient**. SNMP Traps are sent at alarm or error state on the channel. Trap feature can be enabled by option **Trap enabled**.

Back
Exit to main menu

Settings SNMP

General
General device settings

Protocols
Syslog and ModbusTCP protocol settings

SNMP
SNMPv1 protocol and SNMP Traps

Time
Synchronization with NTP server

WWW and Security
Web server and Security configuration

SNMP
Configuration of the SNMPv1 protocol and SNMP Traps. Current measured values can be read using SNMP protocol. When alarm on channel occurs a warning message (Trap) can be sent to selected IP addresses.

SNMP read community

System location

Trap enabled

IP address of the Trap recipient 1

IP address of the Trap recipient 2

IP address of the Trap recipient 3

Apply settings Cancel changes

Time

Time synchronization with SNTP server can be enabled by **Time synchronization enabled** option. IP address of the SNTP is necessary to set into **SNTP server IP address** item. List of free NTP servers is available at www.pool.ntp.org/en. SNTP time is synchronized at UTC format, and due to be necessary set corresponding time offset - **GMT offset [min]**. Time is

synchronized every 24 hours by default. Option **NTP synchronization every hour** decrease this synchronization interval to one hour.

Back
Exit to main menu

Settings

General
General device settings

SNMP
SNMPv1 protocol and SNMP Traps

Time
Synchronization with NTP server

WWW and Security
Web server and Security configuration

MinMax memory
Timestamps, clear memory

Backup
Save or restore configuration

Maintenance
Factory defaults, info, etc.

Time

Time can be synchronized according the SNTP server. To correct time is necessary set GMT offset of your time zone. Time synchronisation is required for timestamps inside CSV files.

Time synchronised with server yes (at 13:50:48 2017-10-23)

Time synchronization enabled

SNTP server IP address

GMT offset [min]

NTP synchronization every hour

WWW and security

Security features can be enabled by the **Security enabled** option. When security is enabled it is necessary to set administrator password. This password will be required for device settings. When secured access is required even to actual values reading it is possible to enable **User account only for viewing**. Port of the www server can be changed from the default value 80 using filed **WWW port**. Web pages with actual values are refreshed according to **Web refresh interval** field.

Back
Exit to main menu

Settings

General
General device settings

Time
Synchronization with NTP server

WWW and Security
Web server and Security configuration

MinMax memory
Timestamps, clear memory

Backup
Save or restore configuration

Maintenance
Factory defaults, info, etc.

WWW and Security

Security
Configuration of the secure access to the device. Administrator password must be inserted if security is enabled. Administrator password is used for device configuration. User password is used only for measured values viewing.

Security enabled

Web server
Configuration of the embedded web server. Web server can be disabled by TSensor software.

Web server enabled

WWW port

Web refresh interval

Memory for minimal and maximal values

Minimal and maximal measured values are stored into the memory. This memory is independent from values stored in history memory (charts). Memory for minimal and maximal values is cleared in case of device restart or by the user request. In case of device time is synchronized with SNTP server, timestamps for minimal and maximal values are available.

Backup and restore configuration

Device configuration can be saved into file and restored if needed. Compatible parts of configuration can be uploaded into another device type. Configuration can be moved only within devices at same family. It is not possible restore configuration from p-line Web Sensor into t-line Web Sensor and conversely.

Setup using TSensor software

TSensor software is an alternative to web configuration. Some less important parameters are configurable only by the TSensor software.

Parameter **MTU size** can reduce size of the Ethernet frame. Lowering of this size can solve some communication problems mainly with Cisco network infrastructure and VPN. Sensor software can set offset of values at temperature probes. At DSRH humidity probe is possible set correction of the humidity and temperature.

Factory defaults

Factory defaults button set the device into factory configuration. Network parameters (IP address, Subnet mask, Gateway, DNS) are left without changes.

Back
Exit to main menu

Settings

Maintenance

General
General device settings

Network
Basic settings of the network interface

Alarm limits
Configuration of the alarm limits

Channels
General settings of the channels

SOAP protocol
Setup SOAP protocol for database system

Email
Alarm emails configuration

Protocols
Syslog and ModbusTCP protocol settings

SNMP
SNMPv1 protocol and SNMP Traps

Time
Synchronization with NTP server

WWW and Security
Web server and Security configuration

MinMax memory
Timestamps, clear memory

Backup
Save or restore configuration

Maintenance
Factory defaults, info, etc.

Info
Basic informations about device. Find more detailed information on the diagnostic page. Please send the diagnostic file together with request to support.

| | |
|-----------------------|--|
| Device type | P8610 |
| Serial number | 15942942 |
| MAC address | 00-20-4A-A8-9B-D2 |
| Firmware version | 4-5-8-1.3500 / 1.80 |
| Build firmware notice | Bay cat |
| Device uptime | 0 h, 10 min, 38 sec |
| Diagnostic file | 192.168.1.111/diag.log |

Events Logs
Events logs with the system or alarm messages can be downloaded in CSV file format for further analysis. After request confirmation both logs are cleared together.

Alarm events log
System events log
Clear events logs

Restart
Device will be restarted after dialog confirmation. All history values are cleared after restart. Restarting of the device will take a few seconds.

Restart device

Factory defaults
Factory defaults button restores device to factory settings. Network parameters like a IP address, subnet mask and gateway IP will not be changed.

Factory defaults

Network parameters are changed while you close jumper inside the device. After jumper closing it is necessary connect power supply. Factory defaults have no effect to user correction inside probe.

Factory parameters settings:

| Parameter | Value |
|--|--------------------------------|
| SMTP server address | example.com |
| SMTP server port | 25 |
| Alarm email repeat sending interval | off |
| Info email repeat sending interval | off |
| Alarm and Info emails attachment | off |
| Short email | off |
| E-mail recipients addresses | cleared |
| E-mail sender | sensor@websensor.net |
| SMTP authentication | off |
| SMTP user/SMTP password | cleared |
| E-mail sending enabled | off |
| IP addresses SNMP traps recipients | 0.0.0.0 |
| System location | cleared |
| Password for SNMP reading | public |
| Sending SNMP Trap | off |
| Website refresh interval [sec] | 10 |
| Website enabled | yes |
| Website port | 80 |
| Security | off |
| Administrator password | cleared |
| User password | cleared |
| Modbus TCP protocol port | 502 |
| Modbus TCP enabled | yes |
| History storage interval [sec] | 60 |
| SOAP message when alarm occurs | yes |
| SOAP destination port | 80 |
| SOAP server address | cleared |
| SOAP sending interval [sec] | 60 |
| SOAP protocol enabled | off |
| Syslog server IP address | 0.0.0.0 |
| Syslog protocol enabled | off |
| SNTP server IP address | 0.0.0.0 |
| GMT offset [min] | 0 |
| NTP synchronization every hour | off |
| SNTP synchronization enabled | off |
| MTU | 1400 |
| Periodic restart interval | off |
| Demo mode | off |
| Upper limit | 50 |
| Lower limit | 0 |
| Hysteresis – hysteresis for alarm clearing | 1 |
| Delay – time-delay of alarm activation [sec] | 30 |
| Channel enabled | all channels |
| Unit on the channel | °C or %RH according used probe |
| Channel name | Channel X (where X is 1 to 5) |
| Device name | Web sensor |

Communication protocols

Short introduction to communication protocols of the device. To use some communication protocols is necessary software, which can use the protocol. This software is not included. For detailed description of protocols and application notes please contact your distributor.

Website

The device supports displaying of measured values, history graphs and configuration using web browser. History graphs are based on HTML5 canvas. Web browser must support this feature for proper function of graphs. Firefox, Opera, Chrome or Internet Explorer 11 can be used. If the device has IP address **192.168.1.213** type into your browser **http://192.168.1.213**. Using TSensor software or web interface can be set automatic webpages refresh in interval. The default value is 10sec. Actual measured values can be obtained using XML file **values.xml** and JSON file **values.json**.

Values from history can be exported in CSV format. History storage interval can be set using TSensor software or web interface. History is erased after every reboot of the device. Reboot of the device is performed when the power supply is disconnected and also after configuration change.

SMTP – sending e-mails

When measured values are over the set limits, the device allows send e-mail to a maximum of 3 addresses. E-mail is send when alarm condition on the channel is cleared or a measuring error occurs. It is possible to set repeat interval for email sending. For correct sending of e-mails it is necessary to set address of SMTP server. Domain address can be used as SMTP server address too. For proper function of DNS is required to set DNS server IP address. SMTP authentication is supported but SSL/STARTTLS not. Standard SMTP port 25 is used by default. SMTP port can be changed. Contact your network administrator to obtain configuration parameters of your SMTP server. E-mail sent by the device cannot be answered.

SNMP

Using SNMP protocol you can read actual measured values, alarm status and alarm parameters. Via SNMP protocol is also possible to get last 1000 measured values from history table. Writing via SNMP protocol is not supported. It is supported **SNMPv1** protocol version only. SNMP used **UDP port 161**. OID keys description can be found in the MIB table, which can be obtained from device website or from your distributor. The password for reading is factory set to **public**. Filed **System location** (OID 1.3.6.1.2.1.1.6 - sysLocation) is blank by default. The changes can be made using web interface. OID keys:

| OID | Description | Type |
|------------------------------------|---|---------|
| .1.3.6.1.4.1.22626.1.5.1 | Device information | |
| .1.3.6.1.4.1.22626.1.5.1.1.0 | Device name | String |
| .1.3.6.1.4.1.22626.1.5.1.2.0 | Serial number | String |
| .1.3.6.1.4.1.22626.1.5.1.3.0 | Device type | Integer |
| .1.3.6.1.4.1.22626.1.5.2.ch | Measured value (where ch is channel number) | |
| .1.3.6.1.4.1.22626.1.5.2.ch.1.0 | Channel name | String |
| .1.3.6.1.4.1.22626.1.5.2.ch.2.0 | Actual value – text | String |
| .1.3.6.1.4.1.22626.1.5.2.ch.3.0 | Actual value | Int*10 |
| .1.3.6.1.4.1.22626.1.5.2.ch.4.0 | Alarm on channel (0/1/2) | Integer |
| .1.3.6.1.4.1.22626.1.5.2.ch.5.0 | High limit | Int*10 |
| .1.3.6.1.4.1.22626.1.5.2.ch.6.0 | Low limit | Int*10 |
| .1.3.6.1.4.1.22626.1.5.2.ch.7.0 | Hysteresis | Int*10 |
| .1.3.6.1.4.1.22626.1.5.2.ch.8.0 | Delay | Integer |
| .1.3.6.1.4.1.22626.1.5.2.ch.9.0 | Unit | String |
| .1.3.6.1.4.1.22626.1.5.2.ch.10.0 | Alarm on channel – text | String |
| .1.3.6.1.4.1.22626.1.5.2.ch.11.0 | Minimal value on channel | String |
| .1.3.6.1.4.1.22626.1.5.2.ch.12.0 | Maximal value on channel | String |
| .1.3.6.1.4.1.22626.1.5.3.1.0 | SNMP Trap text | String |
| .1.3.6.1.4.1.22626.1.5.4.1.1.ch.nr | History table value | Int*10 |

When alarm occurred a warning messages (trap) can be sent to selected IP addresses. Addresses can be set using TSensor software or web interface. Traps are sent via **UDP** protocol on **port 162**. The device can send following traps:

| Trap | Description | |
|-------------|----------------------------|---|
| 0/0 | Reset of the device | |
| 6/0 | Testing Trap | |
| 6/1 | NTP synchronization error | |
| 6/2 | E-mail sending error | SMTP server login error |
| 6/3 | | SMTP authentication error |
| 6/4 | | Some error occurred during SMTP communication |
| 6/5 | | TCP connection to server cannot be opened |
| 6/6 | | SMTP server DNS error |
| 6/7 | SOAP message sending error | SOAP file not found inside web memory |
| 6/8 | | MAC address can't be obtained from address |
| 6/9 | | TCP connection to server cannot be opened |
| 6/10 | | Wrong response code from the SOAP server |
| 6/11 – 6/15 | Upper alarm on channel | |
| 6/21 – 6/25 | Lower alarm on channel | |
| 6/31 – 6/35 | Clearing alarm on channel | |
| 6/41 – 6/45 | Measuring error | |

Modbus TCP

Device supports Modbus protocol for communication with SCADA systems. Device use Modbus TCP protocol. **TCP port** is set to **502** by default. Port can be changed using TSensor software or web interface. Only two Modbus clients can be connected to device at one moment. Modbus device address (Unit Identifier) can be arbitrary. Modbus write command is not supported. Specification and description of the Modbus protocol is free to download on: www.modbus.org.

Supported Modbus commands (functions):

| Command | Code | Description |
|---------------------------|------|----------------------|
| Read Holding Register (s) | 0x03 | Read 16b register(s) |
| Read Input Register(s) | 0x04 | Read 16b register(s) |

Modbus device registers. Address could be by 1 higher, depending on type used communication library:

| Address [DEC] | Address [HEX] | Value | Type |
|---------------|-----------------|-----------------------------------|--------|
| 39970 | 0x9C22 | 1st two digits from serial number | BCD |
| 39971 | 0x9C23 | 2nd two digits from serial number | BCD |
| 39972 | 0x9C24 | 3rd two digits from serial number | BCD |
| 39973 | 0x9C25 | 4th two digits from serial number | BCD |
| 39974 | 0x9C26 | Device type | uInt |
| 39975 – 39978 | 0x9C27 – 0x9C2A | Actual measured value on channel | Int*10 |
| 39980 – 39983 | 0x9C2C – 0x9C2F | Unit on the channel | Ascii |
| 39985 – 39988 | 0x9C31 – 0x9C34 | Channel alarm state | uInt |
| 39990 – 39999 | 0x9C36 – 0x9C3F | Unused | n/a |
| 40000 | 0x9C40 | Channel 1 temperature | Int*10 |
| 40001 | 0x9C41 | Channel 1 alarm status | Ascii |
| 40002 | 0x9C42 | Channel 1 upper limit | Int*10 |
| 40003 | 0x9C43 | Channel 1 lower limit | Int*10 |
| 40004 | 0x9C44 | Channel 1 hysteresis | Int*10 |
| 40005 | 0x9C45 | Channel 1 delay | uInt |
| 40006 | 0x9C46 | Channel 2 temperature | Int*10 |
| 40007 | 0x9C47 | Channel 2 alarm status | Ascii |
| 40008 | 0x9C48 | Channel 2 upper limit | Int*10 |
| 40009 | 0x9C49 | Channel 2 lower limit | Int*10 |
| 40010 | 0x9C4A | Channel 2 hysteresis | Int*10 |
| 40011 | 0x9C4B | Channel 2 delay | uInt |
| 40012 | 0x9C4C | Channel 3 temperature | Int*10 |
| 40013 | 0x9C4D | Channel 3 alarm status | Ascii |
| 40014 | 0x9C4E | Channel 3 upper limit | Int*10 |
| 40015 | 0x9C4F | Channel 3 lower limit | Int*10 |
| 40016 | 0x9C50 | Channel 3 hysteresis | Int*10 |
| 40017 | 0x9C51 | Channel 3 delay | uInt |
| 40018 | 0x9C52 | Channel 4 temperature | Int*10 |
| 40019 | 0x9C53 | Channel 4 alarm status | Ascii |
| 40020 | 0x9C54 | Channel 4 upper limit | Int*10 |
| 40021 | 0x9C55 | Channel 4 lower limit | Int*10 |
| 40022 | 0x9C56 | Channel 4 hysteresis | Int*10 |
| 40023 | 0x9C57 | Channel 4 delay | uInt |

Description:

| | |
|--------|--|
| Int*10 | registry is in format integer*10 – 16 bits |
| uInt | registry range is 0-65535 |
| Ascii | character |
| BCD | registry is coded as BCD |
| n/a | item is not defined, should be read |

Possible alarm states:

| | |
|----|--------------------------------|
| no | no alarm |
| lo | value is lower than set limit |
| hi | value is higher than set limit |

SOAP

The device allows you to send currently measured values via **SOAP v1.1** protocol. The device sends values in XML format to the web server. The advantage of this protocol is that communication is initialized by the device side. Due to it is not necessary use port forwarding. If the SOAP message cannot be delivered, warning message via SNMP Trap or Syslog protocol is sent. The file with the XSD schema can be downloaded from: <http://cometsystem.cz/schemas/soapP8xxx.xsd>. SOAP message example:

```
<?xml version="1.0" encoding="utf-8"?>
<soap:Envelope xmlns:soap="http://schemas.xmlsoap.org/soap/envelope/"
xmlns:xsi="http://www.w3.org/2001/XMLSchema-instance"
xmlns:xsd="http://www.w3.org/2001/XMLSchema">
  <soap:Body>
    <InsertP8xxxSample xmlns="http://cometsystem.cz/schemas/soapP8xxx.xsd">
      <name>Ethernet Transducer</name>
      <sn>11940986</sn>
      <tmr>60</tmr>
      <kind>4353</kind>
      <c1>
        <v>26.3</v>
        <u>C</u>
        <a>no</a>
        <e>1</e>
      </c1>
      ...
      ...
      ...
      <c5>
        <v>-11000</v>
        <u>n/a</u>
        <a>no</a>
        <e>0</e>
      </c5>
    </InsertP8xxxSample>
  </soap:Body>
</soap:Envelope>
```

| Element | Description | | | | | | | | |
|---------|--|--------|--------|-------|------|-------|------|-------|------|
| <name> | Device description. | | | | | | | | |
| <sn> | Contains the device serial number (an eight digit number). | | | | | | | | |
| <tmr> | SOAP sending interval [sec]. | | | | | | | | |
| <kind> | Device type identification number (code): | | | | | | | | |
| | <table border="1"> <thead> <tr> <th>Device</th> <th>Device</th> </tr> </thead> <tbody> <tr> <td>P8511</td> <td>4352</td> </tr> <tr> <td>P8541</td> <td>4353</td> </tr> <tr> <td>P8510</td> <td>4354</td> </tr> </tbody> </table> | Device | Device | P8511 | 4352 | P8541 | 4353 | P8510 | 4354 |
| Device | Device | | | | | | | | |
| P8511 | 4352 | | | | | | | | |
| P8541 | 4353 | | | | | | | | |
| P8510 | 4354 | | | | | | | | |
| <v> | Actual measured value (a decimal part of number is separated by a dot). Error on channel is signaled by number -11000 or lower. | | | | | | | | |
| <u> | Channel unit. In case of error n/a text is shown. | | | | | | | | |
| <a> | Alarm state, where no – no alarm, hi – high alarm, lo – low alarm. | | | | | | | | |
| <e> | Information about enabled/disabled channel (1 – enabled/ 0 – disabled) | | | | | | | | |

Syslog

The device allows sending text message to selected Syslog server. Events are send using **UDP** protocol on **port 514**. Syslog protocol implantation is according to RFC5424 and RFC5426. Events when Syslog messages are send:

| Text | Event |
|---------------------------|----------------------------|
| Sensor - fw 4-5-8.x | Reset of the device |
| NTP synchronization error | NTP synchronization error |
| Testing message | Test Syslog message |
| Email login error | E-mail sending error |
| Email auth error | |
| Email some error | |
| Email socket error | |
| Email dns error | |
| SOAP file not found | SOAP message sending error |
| SOAP host error | |
| SOAP sock error | |
| SOAP delivery error | |
| SOAP dns error | |
| High alarm CHx | Upper alarm on channel |
| Low alarm CHx | Lower alarm on channel |
| Clearing CHx | Clearing alarm on channel |
| Error CHx | Measuring error |

SNTP

The device allows time synchronization with NTP (SNTP) server. SNMP protocol version 3.0 is supported (RFC1305). Time synchronization is made every 24 hours. Time synchronization every hour can be enabled. For time synchronization it is necessary set IP address to the SNTP server. It is also possible set GMT offset for correct time zone. Time is used in graphs and history CSV files. Maximum jitter between two time synchronization is 90sec at 24 hours interval.

Software development kit

Device provides on own web pages documentation and examples of usage protocols. SDK files are available at library page (About – Library).

| SDK File | Note |
|------------|---|
| snmp.zip | Description of SNMP OID's and SNMP Traps, MIB tables. |
| modbus.zip | Modbus registers numbers, example of get values from the device by Python script. |
| xml.zip | Description of file values.xml, examples of values.xml file, XSD schematic, Python example. |
| json.zip | Description of values.json file, example of values.json file, Python example. |
| soap.zip | Description of SOAP XML format, example of SOAP messages, XSD schematic, examples of get SOAP values at .net, PHP and Python. |
| syslog.zip | Description of syslog protocol, simple syslog server in Python. |

Troubleshooting

The chapter describes the common problems with thermometer Web Sensor P8510, Web Sensor P8511 and Web Sensor P8541 and methods how to fix these problems. Please read this chapter before you will call technical support.

I forgot the device IP address

IP address is factory set to **192.168.1.213**. If you had changed it and forgot new IP address, run the TSensor software and press **Find device...** In the window are displayed all available devices.

I cannot connect to the device

In search window is only IP and MAC address displayed

Other details are marked **N/A**. This problem occurs if IP address of the device is set to another network.

Select the window **Find device** in TSensor software and press **Change IP address**. Follow the software instructions. To assign IP address automatically using DHCP server, set the device IP address to **0.0.0.0**.

Device IP address is not displayed in window Find device

In TSensor software menu press **Help! My device was not found!** in window **Find device**. Follow the software instructions. MAC address of the device can be found on product label.

The device is not found even after manually setting MAC address

This problem occurs especially in cases when the IP address of the device belongs to another network and also Subnet mask or Gateway are incorrect.

In this case is DHCP server in the network necessary. In TSensor software menu press **Help! My device was not found!** in window **Find device**. As new IP address set **0.0.0.0**. Follow the software instructions. An alternative is to reset device to factory defaults using factory-defaults jumper.

Error or n/a is displayed instead the measured value

Value **n/a** is shown a shortly after device restart. If the error code or **n/a** is displayed permanently, check if the probes are connected to device correctly. Make sure that probes are not damaged and are inside operating range. Than perform new search of probes using TSensor software or web interface. List of error codes:

| Error | Code | Description | Note |
|---------|--------|--|--|
| n/a | -11000 | Value is not available. | Code is shown after device restart or when channel is not enabled for measurement. |
| Error 1 | -11001 | No probe was detected on measurement bus. | Make sure that probes are connected properly and cables are not damaged. |
| Error 2 | -11002 | Short circuit on measurement bus was detected. | Please make sure that cables of probes are not damaged. Check if correct probes are connected. Probes Pt100/Pt1000 and Ni100/Ni1000 cannot be used with this device. |
| Error 3 | -11003 | Values cannot be read from probe with ROM code stored in device. | According ROM code on probe label please make sure that is connected proper probe. Please make sure that cables of probes are not damaged. Probes with new ROM code is necessary detect again. |
| Error 4 | -11004 | Communication error (CRC). | Make sure that cables of probe are not damaged and cables are not longer than is allowed. Make sure that cable of probe is not located near the source of EM interferences (power lines, frequency inverters, etc.). |
| Error 5 | -11005 | Error of minimal measured values from probe. | Device measured lower or higher values than is allowed. Please check place of probe installation. Make sure that probe is not damaged. |
| Error 6 | -11006 | Error of maximal measured values from probe. | |
| Error 7 | -11007 | Power supply error at humidity probe or measurement error at temperature probe | Contact technical support. Please send together with issue description the diagnostic file \diag.log. |
| Error 8 | -11008 | Voltage measurement error at humidity probe. | |
| Error 9 | -11009 | Unsupported probe type. | Please contact technical support of local distributor to get firmware update for the device. |

I forgot the password for setup

Please reset device to factory defaults. Procedure is described at following point.

Factory defaults

This procedure restore device to factory settings including network parameters (IP address, Subnet mask, etc.). For factory-defaults follow these steps:

P85xx Web sensors

- disconnect the power supply
- unscrew upper cover of the device case
- close the jumper and connect the power
- keep jumper closed for 10sec then remove jumper
- close the device

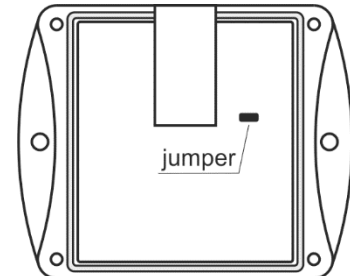

P85xx-HW02 Web sensors

- disconnect the power supply
- use something with thin tipped (e.g. paper clip) and press the hole on the left side
- connect the power, wait for 10 sec and release the button

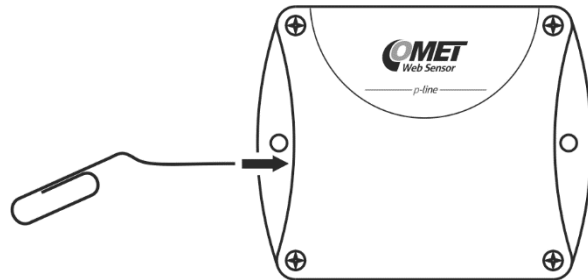

Technical specifications

Information about technical specifications of the device.

Dimensions

Web Sensor P8510:

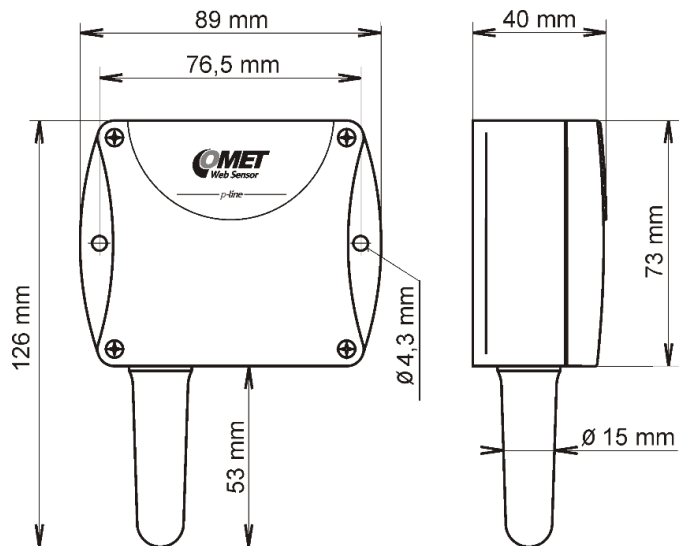

Web Sensor P8510-HW02:

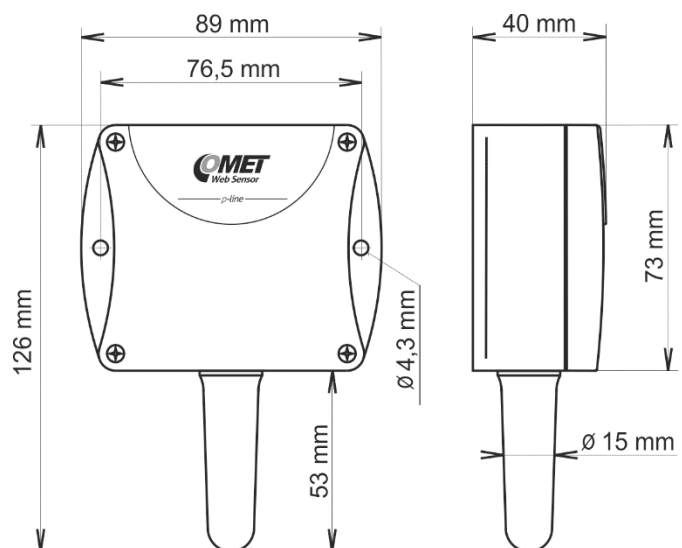

Web Sensor P8511:

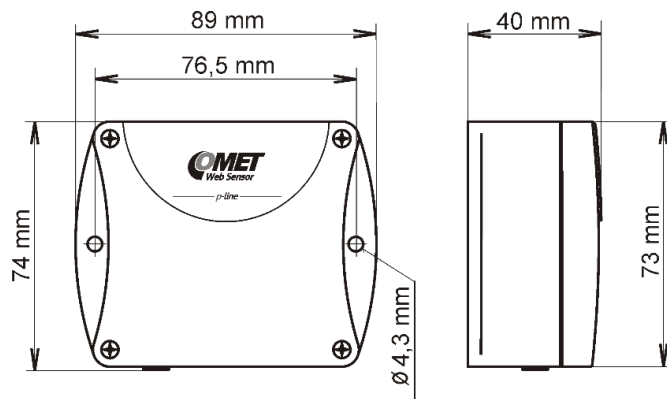

Web Sensor P8541:

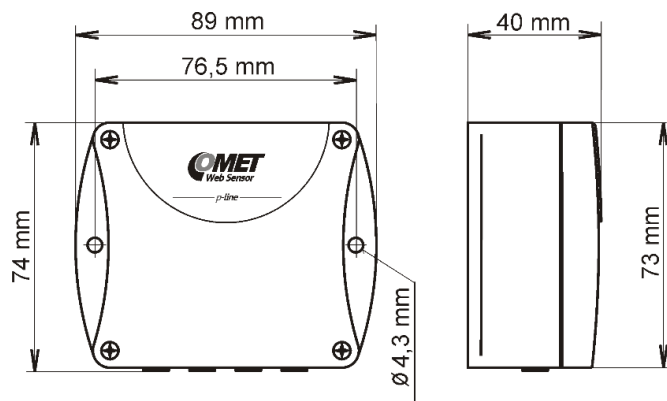

Basic parameters

Supply voltage:

DC voltage from 4.9V to 6.1V, coaxial connector, 5x 2.1mm diameter, center positive pin, min. 250mA

Consumption:

~ 1W depending on the operating mode

Protection:

IP30 case with electronic

Measuring interval:

2sec

Accuracy P8510:

$\pm 0.8^{\circ}\text{C}$ in temperature range from -10°C to $+80^{\circ}\text{C}$

$\pm 2.0^{\circ}\text{C}$ in temperature range from -10°C to -30°C

Accuracy P8511, P8541 (depending on used probe – e.g. probe DSTG8/C parameters):

$\pm 0.5^{\circ}\text{C}$ in temperature range from -10°C to $+85^{\circ}\text{C}$

±2.0°C in temperature range from -10°C to -50°C

±2.0°C in temperature range from +85°C to +100°C

Resolution:

0.1°C

0.1%RH

P8510 temperature measurement range:

-30°C to +80°C

P8511 and P8541 temperature measurement range (limited by range of used probe):

-55°C to +100°C

Recommended probe for P8511 and P8541:

Temperature probe DSTR162/C max. length 10m

Temperature probe DSTGL40/C max. length 10m

Temperature probe DSTG8/C max. length 10m

Humidity probe DSRH max. length 5m

Humidity probe DSRH/C

Number of channels:

P8510 one internal temperature sensor (1 measurement channel)

P8511 one cinch/RCA connector (2 measurement channels)

P8541 four cinch/RCA connectors (4 measurement channels)

Communication port:

RJ45 connector, 10Base-T/100Base-TX Ethernet (Auto-Sensing)

Recommended Connector Cable:

for industrial use is recommended Cat5e STP cable, in less demanding applications can be replaced by Cat5 cable, maximum cable length 100m

Supported protocols:

TCP/IP, UDP/IP, ARP, ICMP, DHCP, TFTP, DNS

HTTP, SMTP, SNMPv1, ModbusTCP, SNTP, SOAPv1.1, Syslog

SMTP protocol:

SMTP authentication – AUTH LOGIN

Encryption (SSL/TLS/STARTTLS) is not supported

Supported web browsers:

Internet Explorer 11, Mozilla Firefox 55 and later, Google Chrome 60 and later, Microsoft Edge 25 and later

Recommended minimum screen resolution:

1024 x 768

Memory:

1000 values for each channel inside non-backup RAM memory
100 values in alarm events log inside non-backup RAM memory
100 values in system events log inside non-backup RAM memory

Case material:

ASA

Mounting the device:

With two holes at the bottom of the unit

Weight:

P8510 ~ 130g, P8511 ~ 125g, P8511 ~ 135g

EMC emission:

EN 55022, Class B

EMC resistance:

EN 61000-4-2, levels 4/8kV, Class A
EN 61000-4-3, intensity of electromagnetic field 3V/m, Class A
EN 61000-4-4, levels 1/0.5kV, Class A
EN 61000-4-6, intensity of electromagnetic field 3V/m, Class A

Operating terms

Temperature and humidity range in case with electronic:

-30°C to +80°C, 0 to 100%RH (no condensation)

Temperature range of recommended probe DSTR162/C for P8511 and P8541:

-30°C to +80°C, IP67

Temperature range of probe DSTGL40/C for P8511 and P8541:

-30°C to +80°C, IP67

Temperature range of probe DSTG8/C for P8511 and P8541:

-50°C to +100°C, IP67

Temperature and humidity range of probe DSRH for P8511 and P8541:

0°C to +50°C, 0 to 100%RH

Temperature and humidity range of probe DSRH/C for P8511 and P8541:

0°C to +50°C, 0 to 100%RH

P8510 working position:

with sensor cover downwards. When mounting in RACK 19" with universal holder MP046 (accessories) then sensor cover can be placed horizontally.

P8511and P8541 working position:
arbitrary

End of operation



Disconnect the device and dispose it according to current legislation for dealing with electronic equipment (WEEE directive). Electronic devices must not be disposed of with your household waste and need to be professionally disposed.

Technical support and service

Technical support and service is provided by distributor. Contact is included in warranty certificate.

Preventive maintenance

Make sure the cables and probes are not damaged periodically. Recommended calibration interval is 2 years. Recommended calibration interval for device with humidity probe DSRH and DSRH/C is 1 year.

Optional accessories

This chapter contains list of optional accessories, which can be ordered by extra cost. Manufacturer recommends using only original accessories.

Temperature probe DSTR162/C

Temperature probe -30 to +80°C with a digital sensor DS18B20 and with Cinch connector for Web Sensor P8511 and Web Sensor P8541. Accuracy $\pm 0.5^{\circ}\text{C}$ from -10 to +80°C, $\pm 2^{\circ}\text{C}$ below -10°C. Length of the plastic case 25mm, diameter 10mm. Guaranteed watertight (IP67), sensor connected to PVC cable with lengths 1, 2, 5 or 10m.

Temperature probe DSTGL40/C

Temperature probe -30 to +80°C with a digital sensor DS18B20 and with Cinch connector for Web Sensor P8511 and Web Sensor P8541. Accuracy $\pm 0.5^{\circ}\text{C}$ from -10 to +80°C, $\pm 2^{\circ}\text{C}$ below -10°C. Steel steel case with length 40mm, diameter 5.7mm. Stainless steel type 17240. Guaranteed watertight (IP67), sensor connected to PVC cable with lengths 1, 2, 5 or 10m.

Temperature probe DSTG8/C

Temperature probe -50 to +100°C with a digital sensor DS18B20 and with Cinch connector for Web Sensor P8511 and Web Sensor P8541. Maximum temperature of the probe is 125°C. Probe accuracy $\pm 0.5^{\circ}\text{C}$ from -10 to +85°C, else $\pm 2^{\circ}\text{C}$. Steel steel case with length 40mm, diameter 5.7mm. Stainless steel type 17240. Guaranteed watertight (IP67), sensor connected to silicone cable with lengths 1, 2, 5 or 10m.

Humidity probe DSRH

DSRH is a relative humidity probe with Cinch connector for Web Sensor P8511 and Web Sensor P8541. Relative humidity accuracy is $\pm 3.5\%RH$ from 10%-90%RH at 25°C. Temperature measuring accuracy is $\pm 2^{\circ}\text{C}$. Operating temperature range is 0 to +50°C. Probe length 88mm, diameter 18mm, connected to PVC cable with lengths 1, 2 or 5m.

Humidity-temperature probe DSRH/C

DSRH/C is compact probe for measurement of relative humidity and temperature. Relative humidity accuracy is $\pm 3.5\%RH$ from 10%-90%RH at 25°C. Temperature measuring accuracy is $\pm 0.5^{\circ}\text{C}$. Operating temperature range is 0 to +50°C. Probe length is 100mm and diameter is 14mm. Probe is designed to be directly mounted to device without cable.

Power supply Adapter A1825

Power supply adapter with CEE 7 plug, 100-240V 50-60Hz/5V DC, 1.2A for Web Sensor P8511 and Web Sensor P8541.

UPS for DC device UPS-DC001

UPS 5-12V DC 2200mAh for up to 5 hours backup for Web Sensor.

Device case holder for RACK 19" MP046

MP046 is a universal holder for mounting of thermometer Web Sensor P8510 and Web Sensor P8511, P8541 to RACK 19".

Probes holder for RACK 19" MP047

Universal holder for easy mounting probes in RACK 19".

Comet database

Comet database provide a complex solution for data acquisition, alarm monitoring and measured data analyzing from Comet devices. Central database server is based on MS SQL technology. Client-server conception allows to easy and instant access to data. Data are accessible from multiple places by the Database Viewer software. One license of Comet Database includes also one license for Database Viewer.