







Multichannel Voltage Recorder MCR-4V

User's Manual

Thank you for purchasing our product.

This manual provides explanations of the installation and operation of the MCR-4V.

Please make sure the following items are included in the package.

 <p>MCR-4V x 1 unit</p>	 <p>MCR for Windows CD-ROM x 1</p>
 <p>USB Mini-B Cable US-15C x 1</p>	 <p>AA Alkaline Battery LR6 x 2</p>
 <p>User's Manual Set (Warranty Included)</p>	 <p>Card Slot Cover x 1</p>

Important Notices and Disclaimers

In order to properly use this product, please carefully read this manual before using.

- All rights of this manual belong to T&D Corporation. It is prohibited to use, duplicate and/or arrange a part or whole of this manual without the permission of T&D Corporation.
- Microsoft and Windows are registered trademarks of Microsoft Corporation in the United States and/or other countries.
- Specifications, design and other contents outlined in this manual are subject to change without notice.
- Please follow the safety precautions outlined in this manual carefully.
- We cannot guarantee nor are we responsible for safety if this product is used in any manner other than was intended.
- On-screen messages in this manual may vary slightly from the actual messages.
- Please notify the shop where you purchased this product or T&D Corporation of any mistakes, errors or unclear explanations in this manual.
- T&D Corporation accepts no responsibility for any damage or loss of income caused by the use of our product.
- This product has been designed for private or industrial use only.
- It is not for use in situations where strict safety precautions are necessary such as in connection with medical equipment, whether directly or indirectly.
- We are not responsible for any malfunction or trouble caused by the use of our product or by any problem caused by the use of measurement results of our unit. Please be fully aware of this before using our product.
- This manual cannot be reissued, so please keep it in a safe place.
- Please read the warranty and provisions for free repair carefully.



Safety Precautions and Instructions

Safety Precautions and Instructions



The following items should be strictly obeyed for the safe usage of this product, and for protecting yourself and other people from bodily harm and/or damage to property.

Explanation of Symbols

Warning Symbols

 DANGER	Failure to follow the instructions with this symbol could cause serious injury or even death.
 CAUTION	Failure to follow the instructions with this symbol could cause personal injury or physical damage to equipment.

Picture Symbols

	Denotes an important warning or caution.
	Denotes a forbidden action.
	Denotes an action that should be carried out.

**DANGER****To Prevent Serious Accidents**

Do not disassemble, repair or modify the unit and accessories.



Do not use the unit in any environment that is exposed to chemicals and harmful gases. Doing so may cause corrosion and/or other danger to the unit. Also, coming in contact with hazardous substances may cause bodily harm to the user or people nearby.



This unit is not water resistant. If water or a foreign object enters the case, immediately unplug the AC adaptor and stop using it.



Do not handle the unit, remove batteries or cables with wet hands.



This product has been designed for private and/or industrial use only. It should not be used in situations where strict safety precautions are necessary such as with medical equipment, or in systems directly or indirectly connected with human life or well-being.



Do not drop or expose the unit to a strong impact.



Do not cut or process the cords for the communication cables. Also, do not twist, pull on or swing any of the cords.



To prevent damage to the unit from static electricity, remove static electricity from your body by touching metal around you (such as a door knob and window frame) before touching the unit.



Place and store the unit and accessories out of the reach of children.



Do not use any power, battery, sensor, or cable other than those specified by T&D Corporation.



We are not responsible for any damage, malfunction or trouble, whether direct or indirect, caused by the use of our product.



Do not put anything on top of the cable. This may cause overheating.



Do not disconnect the USB cable during USB communication. Doing so may cause adverse effects to the unit and/or PC.



Make sure that all cable plugs are inserted fully, so as not to cause an improper connection. Also, when unplugging the cable from the unit, do not pull the cord, but hold the connector to disconnect.



If the unit produces heat, emits smoke or a strange smell, or makes unusual noises, immediately remove the batteries, unplug the power, and stop using it. Also, unplug the unit from the PC.



If the unit is not to be used for a long period of time, remove batteries. If left in the unit, the batteries may leak and lead to malfunctioning. Install new batteries when starting or re-starting to use a unit.



If there is a possibility that high voltage pulses which exceed the measurement range may be applied, make ground connections, either directly or with the surge arrester.



Make sure that there is no magnetic media or materials within one meter from the device.

Magnetic materials may cause damage to data stored in magnetic media.



Do not remove the SD card or turn off the power while writing data to the SD card. This may result in damage to data.



Do not apply voltages higher than $\pm 50V$ to the earth or terminals. It may cause electrification or malfunction.

**CAUTION****Do not place or store in the following areas:**

- Areas exposed to direct sunlight
- Areas exposed to excessive heat or high temperatures such as near fire or heating equipment
- Areas exposed to static electricity
- Areas exposed to strong magnetic fields
- Areas exposed to dampness
- Areas subject to condensation or wet areas
- Areas exposed to excessive vibration
- Areas exposed to excessive smoke, dust or dirt.

**CAUTION****Other Precautions**

- Use the unit in the specified operating environment. Do not use it for any purpose other than for which it was designed.
- Condensation may occur inside the case when a unit is moved from one environment to another where there is a great difference in temperature.
- Do not use the unit in wet areas or places exposed to water such as bathroom.
- When connecting the unit to your PC, make sure to follow all warnings and directions from your computer manufacturer.
- We shall not guarantee the unit's operation if it has been connected to a PC using a USB hub or a USB extension cable.
- Please take extra caution when plugging in and pulling out the USB plug while another USB device such as CDD or HDD is in operation.
- Do not insert any foreign objects into any of the units' jacks.
- If the unit gets dirty, wipe it with a clean cloth.
- Make sure to remove dust and dirt from plugs of any cables.
- Battery terminals may provide insufficient contact due to age or vibration. This may lead to data loss.
- If the unit is not to be used for a long period of time, for safety reasons please remove the battery. If left in the unit, the battery may leak and lead to malfunctioning.
- When an SD card is not inserted, insert the supplied card slot cover to prevent the intrusion of dust.

Before Using this Product

Please be careful about the procedures for Installation.

(For USB communication between your computer and a MCR-4V)

In order to use a USB connection to communicate between the unit and a computer, it is necessary to install the software and the USB device driver.

Make sure to first install the software before connecting the unit to a computer. If you connect the unit first, the USB device driver may not be installed properly.

If you have connected the unit to your computer before installing the software, make sure to click [Cancel] in the Wizard window when it pops up on the computer display. Then disconnect the USB communication cable from the unit.

Table of Contents

Safety Precautions and Instructions	1
--	----------

Before Using this Product	5
--	----------

Overview

Appearance Diagram and Part Names	9
--	----------

Touch Panel	10
-------------------	----

Touch Panel Operation Methods	11
-------------------------------------	----

LCD Display and Icons	12
-----------------------------	----

About How Data is Recorded	14
---	-----------

Using SD Memory Cards	15
------------------------------------	-----------

Supported Memory Cards	15
------------------------------	----

Using MCR-4V

Installing the Battery	17
-------------------------------------	-----------

Usable Power Sources	17
----------------------------	----

Changing the Batteries	17
------------------------------	----

Measuring Voltage	18
--------------------------------	-----------

About the Measurements Display	18
--------------------------------------	----

About the Trend Graph Display	19
-------------------------------------	----

Operating the Trend Graph	20
---------------------------------	----

Increasing Recording Channels	21
--	-----------

About Group Recording with MCR-4V and MCR-4TC	21
---	----

Storage Location for Group Recording	22
--	----

Group Operations via Master	23
-----------------------------------	----

Starting Recording by Group	24
-----------------------------------	----

Stopping Recording by Group	24
-----------------------------------	----

About Menus

[Record Settings] Menu	26
-------------------------------------	-----------

[Data List] Menu	28
-------------------------------	-----------

Displayed Items when Recording Stopped:	28
---	----

Displayed Items during Endless Recording:	29
---	----

[Memory Card] Menu	30
---------------------------------	-----------

[Operation Settings] Menu	30
--	-----------

Explanation of Items in Each Menu	31
[Record Settings] Menu Items	31
[Data List] Menu Items (when recording stopped)	38
How to Read Recorded Data Graph	39
[Data List] Menu Items (during endless recording)	42
[Memory Card] Menu Items	44
[Operation Settings] Menu Items	45

Using a PC with MCR-4V

Installing the Supplied Software	47
Connecting the Device to a PC	49
Making Settings via PC	50
Channel Name	50
Scale Conversion Equation	50
Unit Settings	50
Downloading Recorded Data to a PC	51
Download Recorded Data using “MCR for Windows”	51
Recorded Data File	52
Download Recorded Data from all Connected MCR-4V Units	53
Analyzing Recorded Data	54
Open Recorded Data	54
Print Graphs	54

Other

Troubleshooting	55
Specifications	60
MCR-4V	60
Software (MCR for Windows)	62
Option	62

Overview

The MCR-4V is a multi-channel voltage data logger. It measures and records voltage, and the data can be easily displayed in graph form, enabling the immediate on-the-spot checking of continually-changing data.

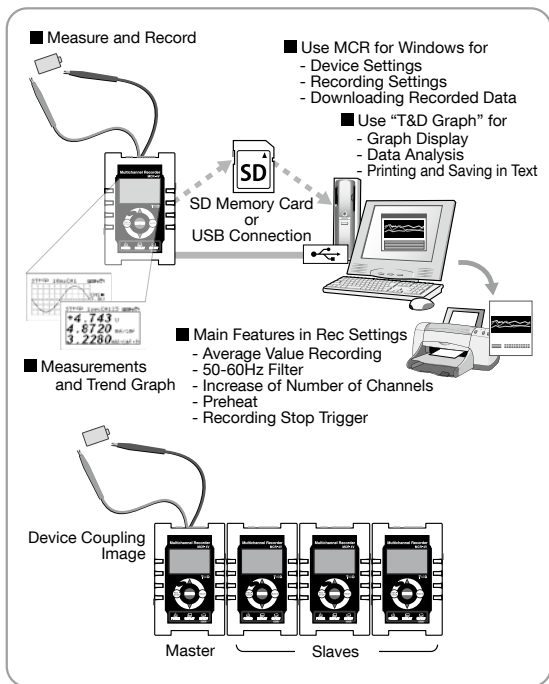

Appearance Diagram and Part Names

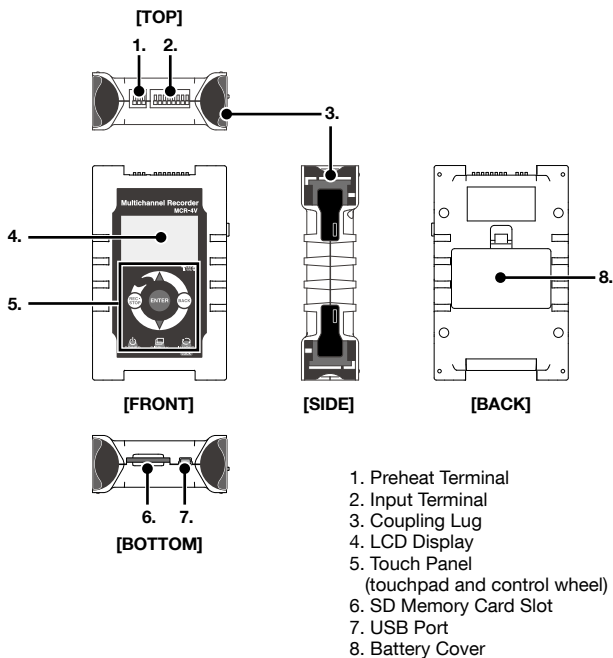

Throughout this manual, the MCR-4V is also referred to as “the device” or “the unit”.

Touch Panel



Press to change the selected menu or settings item (by going up or down), and to increase or decrease the values shown in the LCD.



Press to confirm the selected menu, operation, or value.



Press to jump to the [Start Recording] or [Stop Recording] menu.*



Press to return to the previous screen in the menu* or cancel the current operation.*



Press and hold to turn the power ON/OFF.



Press to switch the display between [Menu] - [Measurements] - [Trend Graph].



Press to switch between the touchpad operation and control wheel operation. Press and hold to switch the key lock ON/OFF.

* Will not function when operating by control wheel.

Touch Panel Operation Methods

There are two ways to operate the touch panel as follows:

- Touchpad operation
- Control wheel operation

Terms and gestures related to operations



Tap (touch)

Tap desired area of touch panel.



Press-and-hold (hold down)

Touch the screen and hold finger in place for a few seconds. Mainly used to switch ON/OFF the power and key lock.



Control Wheel Operation (rotate)

Press and rotate the control wheel (white circular area). Clockwise movement moves ▲ (up) and counter-clockwise movement moves ▼ (down).

IMPORTANT

- During operation, if none of the above gestures are performed for a while, the operation will be canceled and the screen will return to the original value or previous screen.
- Make sure to use a bare finger to operate the touch panel. If you use the tip of your fingernail, gloves, or touch pen, touch panel operations may not be recognized.

Auto Power Off Function

If the device is not used for about three minutes, it will automatically turn off to save battery power. However, the Auto Power Off function will be disabled in any of the following situations.

- When a recording session is in progress
- When measurements or trend graphs are displayed on the screen
- When running on external power

LCD Display and Icons

The following contains some brief explanations about icons. Each menu will be explained later in the “Menu List” pages.

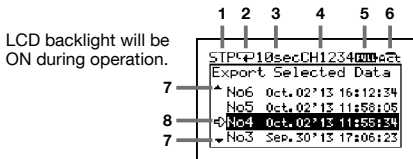







LCD backlight will be ON during operation.

A highlighted display shows the item currently selected, and a blinking highlight shows that an item is being changed.

1 Recording Status	Shows the recording status. REC : Recording in progress STP : Recording stopped PRG : Waiting for programmed start IMM : Preparing immediate start TRG : Stopped by trigger
2 Recording Mode	Shows the recording mode. : Endless mode : One-Time mode
3 Recording Interval	Shows the recording interval. ms : millisecond(s) sec : second(s) min : minute(s) When the recording method is Average, “Aver.” and the recording interval are displayed alternately. When the recording method is Ave.Fine, “Ave.f” and the recording interval are displayed alternately.
4 Recording Channels	Shows the channel(s) being measured and recorded.
5 Battery Mark	Shows source of power and battery level / Battery Mark (Alternating Display): Running on external power Battery Mark only (see the next page): Running on battery
6 Operation Mode	Shows the operation mode status. : Touchpad operation enabled : Control wheel operation enabled : Touch Panel disabled
7	These indicate that there are more menu items above or below for view. Use and on the touch panel to scroll up and down.
8	An item marked with an arrow denotes it has been selected. Use and on the touch panel to move the arrow up and down. Press <ENTER> to execute the selected operation.

The battery mark shows the battery level as follows.

- : Full or near full power
- : Beginning to lose power
- : Significant loss of power
- : Change batteries as soon as possible
- : Change batteries immediately
- : Not operable with batteries only

Below are some examples of recording conditions and the corresponding estimated battery life.

4 channels, Instantaneous value, 10-ms interval	: About 4.5 days
4 channels, Instantaneous value, 1-sec interval	: About 100 days
4 channels, Instantaneous value, 10-sec interval	: About 130 days
Power OFF	: About 3 years

* Battery life varies depending upon the measurement conditions, operating environment, and battery performance.

About How Data is Recorded

The MCR-4V records measurement data to its internal memory. A recording session is one cycle from recording start to stop, and the MCR-4V can record multiple sessions. The number of recording sessions and number of data readings which can be recorded depends upon the number of channels, the recording interval and other settings. In the “n”th recording session, the remaining memory space is used for recording.

EX: When logging capacity is filled during the 5th recording session:

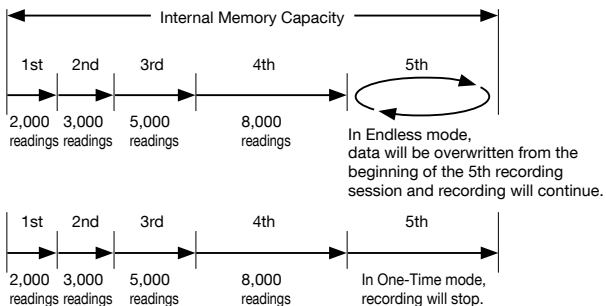

* If the memory capacity has not reached full, up to 30 recording sessions can be made.

Using SD Memory Cards

It is not only possible to transfer data stored in the internal memory to an SD memory card, but it is also possible to automatically backup data while recording in endless mode. Operations related to the use of an SD memory card are as follows:



Exporting Data while Recording is OFF (Manual Saving) See p.38 for details

- [Data List]—[Export Selctd Data]
- [Data List]—[Export All Data]

Exporting Data while Endless Recording is ON (Manual Saving / Automatic Saving) See p.42 for details

- [Data List]—[Expt Curr Data Now]
- [Data List]—[Auto Data Export]

IMPORTANT

- Memory cards are not included. Please purchase separately.
- Measurement data cannot be directly recorded into a memory card.
- Before inserting an SD memory card into the device, make sure to switch off write protection on the memory card.
- Exporting data to the memory card will not erase it from the device's internal memory. Delete recorded data in the device as necessary.

Supported Memory Cards

- SD Memory Cards
- SDHC Memory Cards

IMPORTANT

- SDXC memory cards cannot be used.
- It is possible to run a quick test to see if your memory card works in. See p.44 for details.

Using MCR-4V

The following shows the basic flow of procedures.

MCR Use MCR-4V
PC Use PC

1. Getting Device Ready

Install the batteries (see p.17)

MCR

2. Getting PC Ready

Install the provided software (see p.47)

Connect the device to a PC (see p.49)

PC

3. Setting up the Device (see p.30)/ Making Recording Settings (see p.26)

* Recording Settings can be made both on the device and from a PC.

MCR, **PC**

4. Measuring and Recording

MCR

5. Viewing Recorded Data in Graph on the Device (see p.39)

MCR

6. Downloading Recorded Data to a PC

Exporting data to an SD memory card and transferring to a PC. (see p.38)

Using the supplied software MCR for Windows (see p.51)

* Either of the above can be used to download recorded data to a PC.

MCR, **PC**

7. Analyzing Recorded Data on a PC (see p.54)

View Graph, Print, Save in Text

PC

Installing the Battery

Remove the battery cover from the back of the device, and insert the supplied two AA alkaline batteries as shown in the figure below. After the batteries are inserted, the [Please set the clock] message will appear on the LCD.

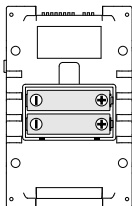

IMPORTANT

- Make sure to use new batteries of the same kind.
- Make sure not to mistake + / -.
- Do not insert or change batteries with wet hands.
- Be sure to completely close the cover.
- The MCR-4V cannot recharge batteries.

Usable Power Sources

- AA Alkaline Batteries
- AA Ni-MH Batteries
- AC Adapter (USB type)
- USB Bus Power

Changing the Batteries

If the battery runs down before it is replaced, MCR-4V will automatically stop recording to protect data. Check the battery mark (see the previous page) and change batteries as necessary.

IMPORTANT

- To protect data, please stop recording first before changing batteries. Not doing so may result in loss of data being recorded.
- When you wish to replace batteries while recording is in progress, make sure to connect the USB cable to your PC for USB bus power.
- If the MCR-4V runs out of power while processing data on a SD memory card, the data on the card may be corrupted.

Measuring Voltage

1. Connect the item to be measured to the MCR-4V using a compatible wire.

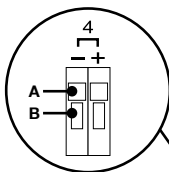

Enlarged View of
Input Terminal



Top Surface

1. Prepare a compatible 10mm strip wire (see Spec).
2. Using a screwdriver or other such tool, while pressing down on the terminal button on the top of the device, insert the wire into the hole <A>.
3. When removing the wire, push down on and gently pull the wire out of the hole <A>.

- * Absolute maximum input voltage is 50V.
- * Maximum measurable input voltage is $\pm 24V$.

2. Press <DISPLAY> to switch the LCD display, and view the measurement and/or trend graph.

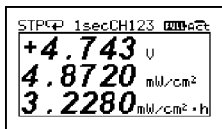

Measurements

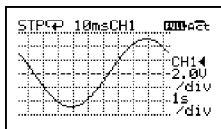

Trend Graph

About the Measurements Display

The font size used to display the measurement automatically changes depending on the number of channels.

- * You can change the number of channels by going to the Main Menu and selecting [Record Settings] > [Rec.Channel]. To change the [Rec.Channel] setting, [Detailed Sett.] needs to be set to ON.
- * When using the scale conversion, the converted value and unit are displayed.

- * You can switch the Scale Conversion ON/OFF by going to [Record Settings] and selecting the desired channel settings (see p.33 “CH1 Settings - CH4 Settings”). Also, the scale conversion equation can be changed via MCR for Windows.

About the Trend Graph Display

A trend graph is displayed for each channel of data.

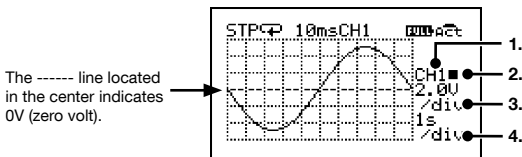

1. Channel for Display

The channel for display can be changed. Select the measurement channel to view the graph.

2. Scrolling Method

- ◀ : Scrolls graph and divisions together.
- : Scrolls graph only.

- * The scrolling method can be switched with <ENTER> when none of 1 to 4 in the above diagram are highlighted or flashing on the LCD.

3. Vertical Voltage Scale (volts/div)

Specify the value for each vertical division in V or mV.

EX) “2.0V/div” shows that each vertical division represents 2.0 V.

4. Horizontal Time Scale (time/div)

Specify the value for each horizontal division in sec or min.

EX) “1s/div” shows that each horizontal division represents 1 sec.

- * **4.** The possible selections for the time scale will change depending on the measurement interval.

Operating the Trend Graph

Use ▲ and ▼ to highlight the desired item, and tap <ENTER>. While the selected item is blinking, use ▲ and ▼ again to change the value, and tap <ENTER>.

- * If no operations are performed or a change is not confirmed with <ENTER> while the selected item is blinking, the operation will be canceled and the selected item will return to the original value.

Increasing Recording Channels

Up to four units can be coupled together to allow for a maximum of 16 channels.

When the bodies of multiple units are connected, the MCR-4V at the far left side will be automatically designated as the Master and all other connected MCR-4V units will be designated as Slaves.

Coupling Image

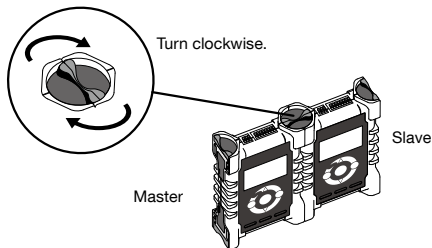

By starting recording on the Master unit, all connected Slave units will start recording at the same time.

Coupling of MCR-4V and MCR-4TC is possible. Refer to the MCR-4TC User's Manual for its operating instructions.

About Group Recording with MCR-4V and MCR-4TC

When using MCR-4V as the Master and MCR-4TC as the Slave:

- The measurement interval of the Slave is determined by the Master, but, Group Recording cannot be started if the measurement interval is less than 100ms.

When using MCR-4TC as the Master and MCR-4V as the Slave:

- The measurement interval of the Slave is determined by the Master.
- The 50-60Hz Filter will be set to ON when recording interval is 500ms or greater, and set to OFF when recording interval is less than 500ms.

Storage Location for Group Recording

When performing a group recording for multiple units, recorded data will be stored in each unit's memory. To analyze recorded data on a PC, either download data using MCR for Windows, or export data to the SD memory card to transfer to a PC.

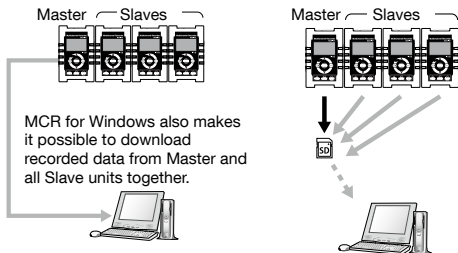

- * All recorded data files downloaded using MCR for Windows will be stored in the same folder by default. See p.52 for the storage location of recorded data and file name.

Group Operations via Master

Group operations such as the starting and stopping recording for the connected units can only be performed via the Master. Upon the start of a group recording, the main recording settings will be temporarily copied to all connected Slaves. Upon the stopping of recording, all copied settings will be returned to their original state.

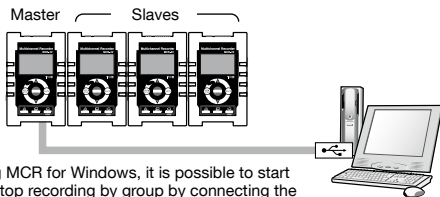

Using MCR for Windows, it is possible to start and stop recording by group by connecting the Master to a PC via USB.

Settings Controlled by the Master:

Settings for Recording Mode, Recording Method, 50-60Hz Filter, Recording Interval, and Recording Channels

Settings not Controlled by the Master:

Settings for Channel Name, Measurement Range, Scale Conversion and Warning Monitoring

Other Settings:

Preheat and Recording Stop Trigger are only enabled on the Master.

IMPORTANT

- Operations related to the SD memory card (such as Data Export and Quick Format) cannot be performed by group via the Master.
- To change settings for items that are not controlled by the Master, either change on the target connected Slave unit, or use MCR for Windows by connecting each Slave unit to the PC with a USB cable.
- Among the above "Settings not controlled by the Master", the Channel Name and Scale Conversion can only be set or changed via MCR for Windows.

Starting Recording by Group

- 1.** Make recording settings for each device separately; no matter if it is a Master or a Slave.

* See p.26 for a list of the possible setting items.

* See p.23 for the settings that are/are not controlled by the Master.

- 2.** From the main menu of the Master, select [Record Settings] - [Start Recording].
- 3.** For the [Method], select [IMMED (grp)] or [PGM (grp)].
- 4.** Select [OK] and tap <ENTER>.

IMPORTANT

All connected Slaves need to have power switched to ON.

Stopping Recording by Group

From the main menu of the Master, select [Record Settings] - [Stop Recording].

IMPORTANT

- During Group Recording, if the bodies of the devices are disconnected from one another, recording will continue on the Master but will stop on the Slave units.
- Even when devices are coupled, power will not be supplied from the Master to any connected Slave units.
- When the Master stops recording, all Slaves will stop recording.
- During recording in one-time mode, if the Slave's memory capacity becomes full, recording will stop on that Slave unit only.

About Menus

[Record Settings] Menu

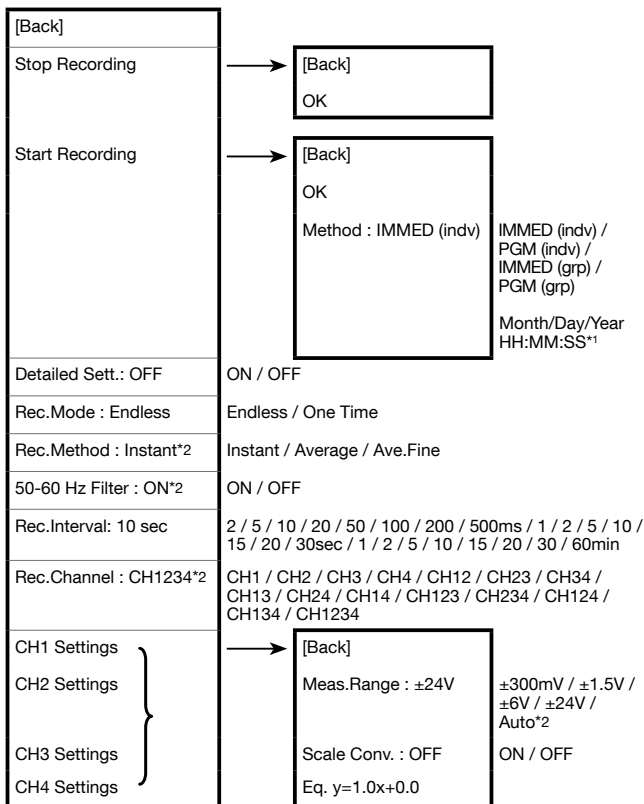

	Unit [V] Warn Montr : OFF Uppr Limit : ---*3 Lwr Limit : ---*3 Judge Time : ---*3	OFF / Lower / Upper / Up&Low User Specified Voltage Value User Specified Voltage Value User Specified Time
Preheat : OFF	OFF /User Specified Time	
Rec.Stop Trigger	[Back] Function : OFF Channel : --- Slope : --- Voltage : --- Stop in : ---	ON / OFF CH1 / CH2 / CH3 / CH4 Rising / Falling User Specified Value User Specified Time
Save/Restore Sett.	[Back] Save Settings1 Save Settings2 Save Settings3 Save Settings4 Restore Settings1 Restore Settings2 Restore Settings3 Restore Settings4	

*1: Will only appear when the recording start method is set to PGM (programmed start).

*2: Will not appear when Detailed Sett. is set to OFF.

*3: Will not appear when Warn Montr (warning monitoring) is set to OFF.

[Data List] Menu

Displayed Items when Recording Stopped:

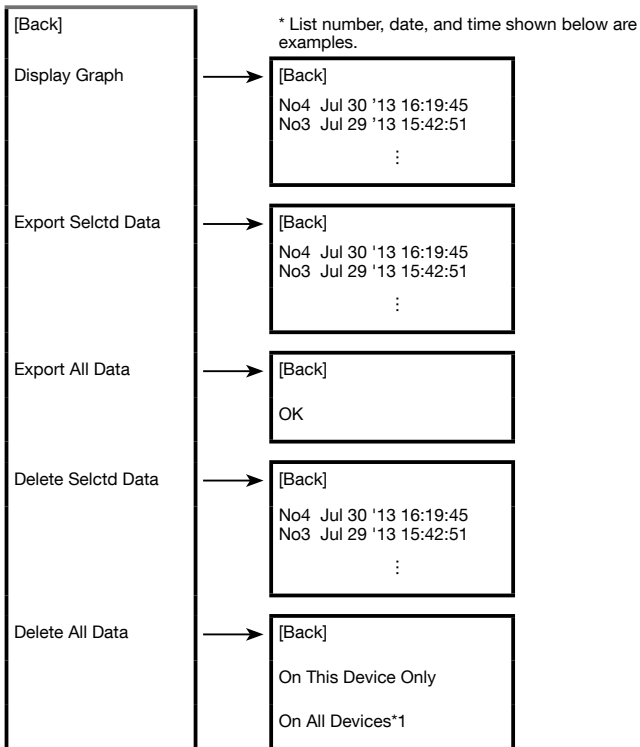

*1: When selecting [Delete All Data] on the Slave unit, the [On All Devices] option will not appear.

Displayed Items during Endless Recording:

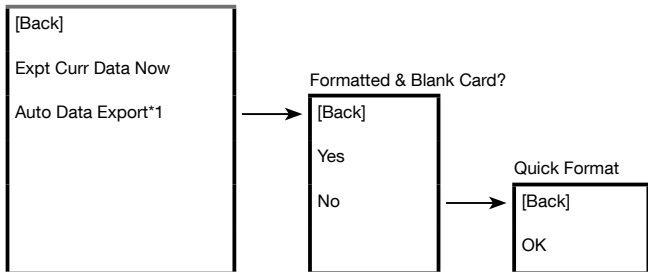

*1: When recording in one-time mode, [Auto Data Export] will not be displayed.

[Memory Card] Menu

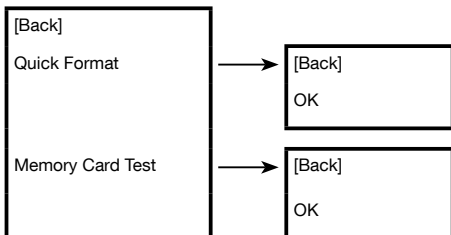

[Operation Settings] Menu

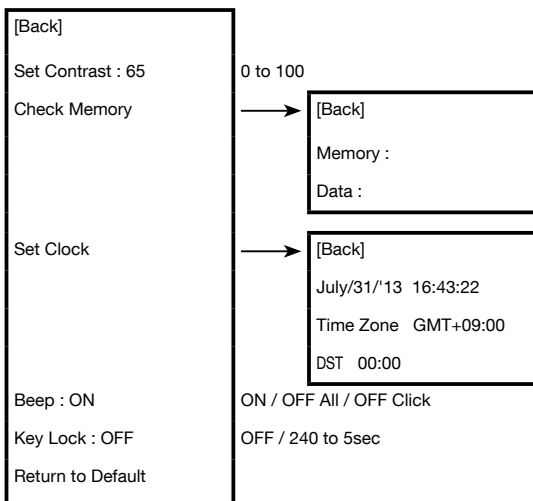

Explanation of Items in Each Menu

[Record Settings] Menu Items

[Stop Recording]

Click [OK] to stop recording.

[Start Recording]

Click [OK] to start recording.

[Method : IMMED(indv) / PGM(indv) / IMMED(grp) / PGM(grp)]

IMMED(indv) : Starts recording immediately.

PGM(indv) : Starts recording on the specified date and time.

IMMED(grp) : Starts Group Recording immediately.

PGM(grp) : Starts Group Recording on the specified date and time.

For details about Group Recording, see p.21.

[Detailed Sett.: ON / OFF]

Switch ON/OFF the detailed settings.

When detailed settings is switched to OFF, the [Rec.Method], [50-60Hz Filter], and [Rec.Channel] menus will not appear on the screen, and the following limitations will be placed on the settings.

Rec. Method (nondisplay)	Fixed to "Instant" (Instantaneous Value)
50-60Hz Filter (nondisplay)	Fixed to OFF when recording interval is 10ms - 200ms, and fixed to ON when recording interval is 500ms - 60min.
Rec. Interval	Not possible for under 10ms
Rec. Channel (nondisplay)	Fixed to 4 channels (CH1234)
Meas. Range	Not possible to select "Auto"

[Recording Mode : Endless / One Time]

Endless: When the internal memory capacity becomes full, the most recent data will be overwritten and recording will continue.

Onetime: Recording will be stopped at the moment the internal memory capacity becomes full.

* See p.14 for an outline of info about recording and memory.

[Rec.Method: Instant / Average / Ave.Fine]

Select the recording method to be used. For information about the sampling interval when recording average values, see the attached document "Sampling Interval for Recording Average Values".

Instant (Value): Records the instantaneous value at the set recording interval.

Average (Value): Records the value as the average of the measurements taken during the set recording interval.

Ave.(Value) Fine: This records the average value for measurements at even shorter measurement interval.

IMPORTANT

- When recording average values, the first recorded value is invalid because an average cannot be calculated.
- If the Preheat function has been set to ON, then only recording of instantaneous values can be selected.
- Recording in the "Ave.Fine" method consumes more power than other methods, resulting in a shorter battery life.

[50-60 Hz Filter : ON / OFF]

Switch ON/OFF the filter function to eliminate 50-60Hz noise.

- * This setting will affect both the shortest possible recording interval and battery life.

[Rec. Interval : (user-specified time)]

Select from 23 choices: 2, 5, 10, 20, 50, 100, 200, 500 msec. / 1, 2, 5, 10, 15, 20, 30 sec. / 1, 2, 5, 10, 15, 20, 30, 60 min. (default setting is 10 min)

However, available choices will differ depending upon the combination of other settings.

[Rec. Channel :]

Select the channel(s) for recording. It is possible to select to record using one channel or a combination of channels from Ch1 - Ch4. The number of channels which can be selected will differ depending upon the combination of other settings.

When the recording interval is less than 1 sec, the number of channels that can be recorded simultaneously varies depending upon the combination of settings made for 50-60Hz Filter and Recording Interval.

		Recording Intervals								
		2ms	5ms	10ms	20ms	50ms	100ms	200ms	500ms	1sec or more 60min
50-60Hz Filter OFF	1ch	✓	✓	✓	✓	✓	✓	✓	✓	✓
	2ch		✓	✓	✓	✓	✓	✓	✓	✓
	3ch			✓	✓	✓	✓	✓	✓	✓
	4ch			✓	✓	✓	✓	✓	✓	✓
50-60Hz Filter ON	1ch						✓	✓	✓	✓
	2ch							✓	✓	✓
	3ch							✓	✓	✓
	4ch								✓	✓

IMPORTANT

- When you select "Auto" as the measurement range, recording intervals of less than 1 second will not be available to be set. If you wish to set the recording interval to less than 1 second, the measurement range must be set to other than "Auto".
- It is not possible to make different recording interval settings for each channel.

[CH1 Settings - CH4 Settings]

The following menus can be set for each channel.

[Meas. Range : $\pm 300\text{mV}$ / $\pm 1.5\text{V}$ / $\pm 6\text{V}$ / $\pm 24\text{V}$ / Auto*]

Select the desired measurement range.

- * Auto is available only when the detailed settings is set to ON.

[Scale Conv. : ON / OFF]

Select whether or not to use scale conversion.

[Eq.]

Shows the scale conversion equation set in MCR for Windows (see p.50). This equation is applied in the measurement displayed in the LCD, trend graph displayed in the LCD, and recorded data graph viewed on a PC.

[Unit]

Shows the measurement unit set in MCR for Windows (see p.50). This unit is used in LCD (measurement display and trend graph) as well as in Graph (downloaded recorded data).

[Warn Montr : OFF / Lower / Upper / Up&Low]

OFF : Does not monitor for warnings.

Lower : Monitors voltage for the set lower limit.

Upper : Monitors voltage for the set upper limit.

Up&Low : Monitors voltage for the set upper and lower limits.

About the Warning Monitoring Function

When the set upper or lower limit is exceeded for the set length of time necessary to be judged as a warning, the MCR-4V will display a warning sign next to the measurement value on the LCD.

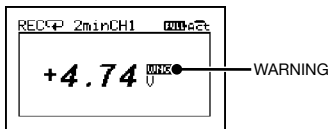

If you wish to turn off the warning **WNG** sign, do one of the following:

- Start a new recording.
- Press and hold the <BACK> button.

IMPORTANT

- When a recording is in progress and the latest recorded value exceeds the set upper or lower limit, the warning **WNG** sign will not go off by pressing and holding the <BACK> button.

[Uppr Limit] / [Lwr Limit]

Specify the criteria for judging a warning : upper limit and lower limit.
This can be set for each channel.

[Judge Time]

Specify the judgement time (time necessary for the measurement to be judged as a warning). When this time is set to 0 (zero), a measurement will be judged as a warning at the moment it exceeds the set upper or lower limit.

[Preheat : OFF / User-Specified Time]

Select whether or not to use the preheat function. When using the preheat function, make settings for the length of time to send current to the sensor.

About the Preheat Function

Preheat is a function which allows the data logger to control power to the connected sensor. It transmits a preheat signal that is synchronized with the recording interval to turn sensors ON before and OFF after measuring and recording.

Other than the sensor ON/OFF function, preheat can also be used to control transient-load battery, lights, heater, and transient signals.

Preheat Time

When using the preheat function, this stands for the length of time to send current to the sensor before measurement and recording is set to occur. When setting the preheat time that is equivalent to or longer than the recording interval, current will be supplied to the sensor at all times.

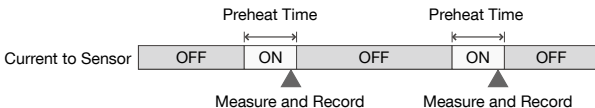

IMPORTANT

- When using the preheat function, the LCD display will be refreshed based on the recording interval set in the device. (this is due to the fact that the sensor is taking no measurements other than at the set recording interval)
- The necessary preheat time varies depending upon the sensor to be used; please check the specifications of the sensor before making settings for the preheat time.

Connection Example

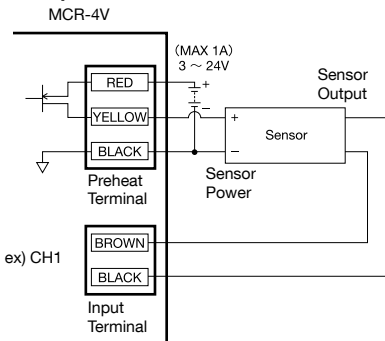

[Rec.Stop Trigger]

To enable the Recording Stop Trigger, set [Function] to ON and carry out the following settings.

[Channel]

Select the channel which will be used for the trigger.

[Slope : Rising / Falling]

When the input signal reaches the set voltage level, select whether to trigger on the rising slope or falling slope of the signal.

[Voltage]

Set the voltage level as the trigger condition.

[Stop in]

Set the delay to stop recording after the trigger condition has been reached.

About the Recording Stop Trigger Function

This is a function to determine when to stop recording. The MCR-4V will stop recording after the set trigger condition has been reached and the set delay time has elapsed.

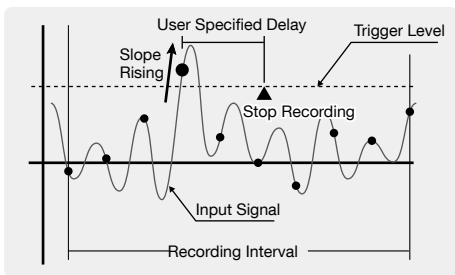

* The necessary conditions for the stop trigger are only detected at the points of input signal measurement; at the point of recording, even if the conditions are met, they will not be detected.

[Save/Restore Sett.]

By selecting [Save Settings], it is possible to save up to 4 types of recording settings. All setting items in the [Record Settings] menu can be saved and re-used, allowing you to save steps to repeat making the same settings each time.

To use the saved recording settings (No.1 to 4), open them by selecting [Restore Settings (No.1 to 4)]. [Restore Settings] screen will show a part of the record settings as below.



* The bottom line of the screen alternately displays the recording channel(s) and 50-60Hz filter setting, then the measurement range. If no operations are performed for a while, the alternating display will stop.

IMPORTANT

- Only settings that have been saved from [Save Settings No.1 to 4] are available for restoring.
- While a recording is in progress, recording settings can only be saved, but not restored.
- ALL saved settings will be deleted by executing [Return to Default] from the [Operation Settings] menu. It is not possible to delete each saved setting individually.

[Data List] Menu Items (when recording stopped)

[Display Graph]

From the displayed list, select data you wish to view in a graph and tap <ENTER>.

[Export Selctd Data]

From the displayed list, select data to export to the SD memory card and tap <ENTER>.

IMPORTANT

- Memory cards are not included. Please purchase separately.
- Multiple data files cannot be selected for exporting.

[Export All Data]

Select [OK] to export all data to the SD memory card.

IMPORTANT

- Before inserting an SD memory card into the device, make sure to switch off write protection on the memory card.
- Exporting data to the memory card will not erase it from the device's internal memory. Delete recorded data in the device as necessary.

Supported Memory Cards

SD Memory Cards

SDHC Memory Cards

IMPORTANT

- SDXC memory cards cannot be used.
- It is possible to run a quick test to see if your memory card works in MCR-4V. See p.44 for details.

[Delete Selctd Data]

 While “Processing” is displayed on the LCD, do not perform any other operations. This process may take a long time to complete.

Select the data you wish to delete from the displayed list, and tap <ENTER>.

- * If no operations are performed for a while on the data list screen, you'll return to the previous screen.
- * Deleting only a few (1-3) data readings from a list which contains a small number of readings may have no effect on memory usage. (see p.45 for how to check memory capacity)

[Delete All Data]

[On This Device Only]:

Select [OK] to delete all recorded data on the device currently in use.

[On All Devices]:

Select [OK] to delete all recorded data on the Master and all connected Slave units all together.

- * If you try to perform this operation on a Slave unit, the [Delete All Data] menu will only show the [On This Device Only] option.

How to Read Recorded Data Graph

The graph can be scrolled on the display by using ▲▼ or control wheel operation to move to the left or right.

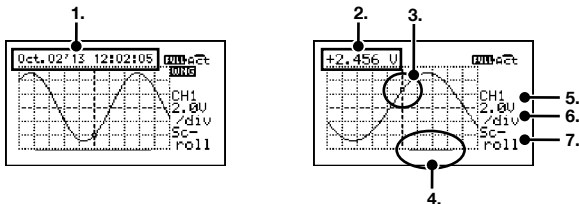

1. While scrolling, the time of recorded data appears on the top of the screen.
2. The time of recorded data will switch to the measurement, a few seconds after you stop scrolling.
3. The measurement shown in 2 is the value of the point located at the center of the graph.
4. The bar on the bottom of the graph shows the portion of the data in the view window.

Tapping <ENTER> allows you to change 5, 6 and 7.

5. Recording Channel

Select the desired channel to view a graph. If the displayed channel has not been used for recording, you will see the "No Record" message.

6. Vertical Axis Scale

Set scaling value for Y-axis divisional boxes.

EX) "2.0V/div" shows that each vertical division represents 2.0 V.

7. Skimming Level (Horizontal Axis Scale)

Set skimming level for X-axis divisional boxes.

Skim \times 1 : The space between dots (data points on graph) is same as the recording interval value

Skim \times n : The space between dots (data points on graph) is "n" times the recording interval value

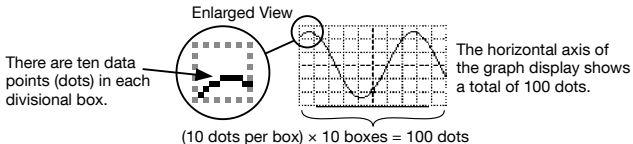

EX1) When recording interval is 10 ms and skimming level is " \times 1":

Each horizontal divisional box represents 100 ms (10 ms \times 1 \times 10 dots) with the total screen width showing 1 sec (100 ms \times 10 boxes) of recorded data.

EX2) When recording interval is 10 ms and skimming level is " \times 2":

Each horizontal divisional box represents 200 ms (10 ms \times 2 \times 10 dots) with the total screen width showing 2 sec (200 ms \times 10 boxes) of recorded data.

Use <ENTER> and <BACK> to move to the target item, then change the value with ▲ and ▼.

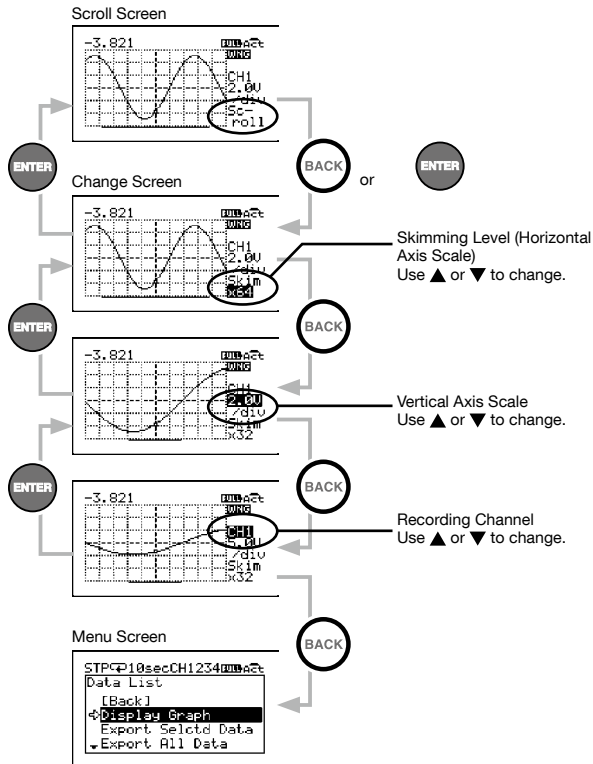

IMPORTANT

When changing settings as above, if no operations are performed or a change is not confirmed with <ENTER>, the change will automatically be applied and the graph will return to the "Scroll" mode.

[Data List] Menu Items (during endless recording)



[Expt Curr Data Now]

Use this to immediately export the data currently being recorded to the SD memory card.

IMPORTANT

Memory cards are not included. Please purchase separately.

[Auto Data Export]

To prevent data loss in Endless mode, this menu will automatically export the data to be overwritten to the SD memory card.

* When the internal memory capacity becomes full in Endless mode, the most recent data will be overwritten and recording will continue.



Make sure to use a formatted blank SD card, or carry out a “Quick Format” (see p.44).

* During the [Auto Data Export] process, other operations cannot be performed except for switching the LCD display between [Menu] - [Measurements] - [Trend Graph] by pressing  .

Canceling [Auto Data Export]

If you wish to cancel the auto data export process, select [Back] and tap <ENTER>.



The displayed message will be cleared when the process is terminated.

Restrictions on [Auto Data Export]

- USB communication cannot be used until the export process has been completed.
-  button is deactivated during the process.
- The export will be terminated in the following cases:
 - When the SD card is full
 - When using a 2GB or smaller SD card formatted as FAT16 and the number of files reaches 128
 - When the SD card is removed
 - When an SD card write error occurs

[Memory Card] Menu Items

[Quick Format]

Select [OK] to format your SD memory card for use in the MCR-4V.

IMPORTANT

- This process will erase all recorded data from the SD memory card. It is recommended to make backups of recorded data to a PC before formatting the memory card.
- It is not possible to erase individual data readings from the SD memory card.
- Do not turn off the power while the device and SD memory card are in communication. If the device is running on batteries, make sure the batteries have power and are installed correctly. If power is supplied by a PC over the USB bus, avoid power supply disruption due to cable disconnection or power-saving settings on the PC.

[Memory Card Test]

Select [OK] to check if your SD memory card can be used with the MCR-4V. Not all commercially available SD memory cards can be used. It is recommended to do this test before using.

IMPORTANT

If the memory card you wish to use passes the test but has problems when using, carry out "Quick Format".

[Operation Settings] Menu Items

[Set Contrast]

Adjust the LCD contrast with ▲ and ▼. Tap <ENTER> to confirm the contrast.

[Check Memory]

You can check the memory usage (% of capacity) and the number of recorded data.

[Set Clock]

1. Tapping ▼ will change the selection item of the display in the order of month, day, year, hour, minute, and second. By tapping <ENTER>, the value for that item will flash.
2. While flashing, use ▲▼ to select the desired value and tap <ENTER> to confirm.
3. Move to the next or previous setting item with ▲ or ▼.

* By tapping <BACK> while the selected item is flashing, the operation will be canceled and flashing will stop.

[Time Zone] and [DST]

Set time zone and daylight savings time (DST) according to the region in which the MCR-4V will be used.

IMPORTANT

- It is not possible to set the clock while recording is in progress.
- Please make sure that the date and time settings in the MCR-4V are correct, if they are not, the recording start time and recording time of downloaded data will be incorrect.
- Clock settings (including time zone and DST) for the MCR-4V can also be made from your computer by using the supplied software MCR for Windows. When making settings via MCR for Windows, it is not necessary to carry out operations from the MCR-4V.

[Beep]



This allows you to turn off the operation confirmation beeping sound.

* The "OFF Click" option will turn off the confirmation sound for touch panel operation only.

[Key Lock]

This function automatically disables the use of the touch panel if no operations occur during a set period of time. It helps prevent handling mistakes.

Use ▲▼ to specify the amount of time before the lock sets (in 1-sec units).

- * If you wish to turn ON the key lock immediately, press and hold  on the touch panel. The lock can be released by pressing and holding  again.

[Return to Default]

By clicking [OK], the device will be initialized by returning it to the factory default settings.

 **This will delete all data stored in the device and initialize the settings. Please be careful when initializing a device as it is not possible, after initialization, to retrieve previous settings info or recover deleted or corrupted data.**

 **Do not turn off the power of the MCR-4V during initialization. Termination of the initialization process may cause damage or malfunction to the device.**

Using a PC with MCR-4V

By using the supplied software, it is possible to make Device Settings and Recording Settings from a computer, as well as download recorded data from the MCR-4V to your computer for graph view and data analysis.

Installing the Supplied Software

The software installation procedure is as follows:

1. Start Windows and login using a User Account with Administrator (Computer Administration) rights.
2. Place the CD-ROM into your CD or DVD drive.
3. The [Install Program] window will appear.

If the [Auto Play] window appears:

Click on [Run start.exe].



If the [Install Program] window does not appear automatically:

Double click on the [start.exe] icon in the CD/DVD drive.

- 4.** Select “Install MCR for Windows” and click [Execute] to start the installation.



- 5.** Follow the directions as they appear to complete the installation.

* If a window appears such as the one below during installation, click [Install] or [Continue Anyway].



After installation, MCR for Windows will appear in the Windows Start Screen or Start Menu.

- 6.** To view recorded data in a graph or print out, go back to step **4.** and install “T&D Graph”.

* For details about operations please see the “Help” menu in the software.

Connecting the Device to a PC

1. Open MCR for Windows from the Start Screen or Start Menu.
2. Connect the device with the supplied USB cable to your computer.
The USB driver installation will start automatically.

IMPORTANT

- Make sure to install the supplied software MCR for Windows before connecting the MCR-4V to the computer.
- The USB device driver must be installed before trying to carry out USB communication. After installing the USB device driver, your computer will be able to detect and recognize any MCR-4V unit that is connected with a USB communication cable.
- When connecting a MCR-4V to a PC, connect only one unit at a time. If you connect multiple units at the same time, they may not be recognized properly.
- For the installation procedure of the software MCR for Windows, see p.47.



When the USB driver installation completes, on the upper right corner of the software screen, you will see an icon showing the PC and MCR-4V connected via USB.

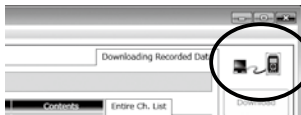

IMPORTANT

If you don't see this icon, the USB driver may not have been installed correctly. Please see [Help for Unit Recognition Failure] in the Help menu, and check the USB driver.

Making Settings via PC

The following items are not included on the device menu, and can only be set or changed from MCR for Windows by connecting the device to a computer via USB.

Channel Name

Create and assign names to each of the channels to be used for recording. Channel Names are used for display in “T&D Graph”.

1. Select the [Recording Start Settings] menu in MCR for Windows.
2. Place a check next to the desired channel(s) and enter each channel name.
3. Click [Send Settings].

Scale Conversion Equation

1. Select the [Scale Conversion / Unit Settings] menu.
2. Place a check next to the desired channel(s).
3. Set “Scale Conversion” to ON for each channel.
4. Select either [Convert by using the equation: $y=ax+b$] or [Convert by specifying 2 points], and enter a value in each box.
5. Select the number of significant digits after scale conversion.
6. Click [Apply Settings].

Unit Settings

1. Select the [Scale Conversion / Unit Settings] menu.
2. Open the “Measurement Unit” tab page, and set [Unit for use in Graph] for display in “T&D Graph” and [Unit for use in LCD] for measurements and graph display in LCD.
3. Click [Apply Settings].

Downloading Recorded Data to a PC

Data stored in the internal memory of MCR-4V can be downloaded to a computer in either of the following two ways:

- Use an SD memory card to export recorded data and transfer to a PC.*
- Use MCR for Windows to download by connecting the device to a PC.

* For how to export recorded data to an SD memory card, see p.38.

IMPORTANT

When recording is in progress, there are restrictions on functions related to the SD memory card.

Download Recorded Data using MCR for Windows

By connecting the device to a PC with a USB communication cable, it is possible to download recorded data to a PC.

1. Open MCR for Windows.
2. Connect the device to your computer.
3. Click [Get List] in the [Downloading Recorded Data] window.



4. Check the desired data in the list.

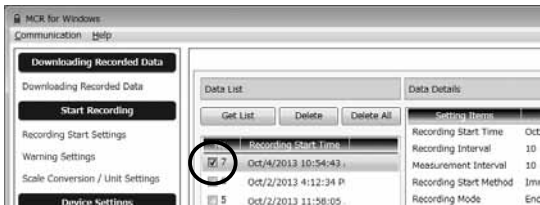

5. Click [Download].



Recorded Data File

One recorded data file (.r4V) is created for each recording session.

Storage Location of Recorded Data and File Name

The default setting is as follows.

Storage Folder:

C:\Users\username\Documents(or My Documents)\TandD Corp\MCR

File Name:

Serial number_rec.month_rec.day_rec.year_rec.time (hhmmss).r4V

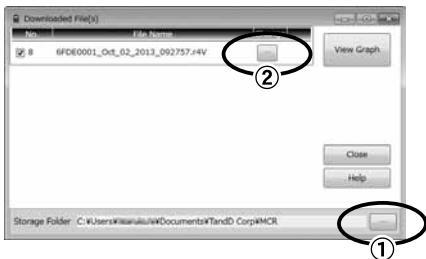

To change the default storage folder, click ① and specify the desired folder. Button ② allows you to specify the desired file name as well as its location.

Download Recorded Data from all Connected MCR-4V Units

- 1.** Connect the Master unit to your computer via USB.
- 2.** Get a data list for the Master. (see p.51)
- 3.** Click [Search for Slave] to get data lists for the connected Slave units.
- 4.** Place a check next to the target data.

* It is possible to select data from both the Master and Slave unit(s) for simultaneous download.

- 5.** Click [Download].

* If it takes too long to download data recorded from Slave units, it is also possible to directly connect a Slave to the PC via USB and download individually. (You can switch the USB cable from the Master to connect a Slave.)

IMPORTANT

Do not disconnect the USB cable during communication between a device and the PC.

Analyzing Recorded Data

Open Recorded Data

In the storage folder for the downloaded recorded data on your PC (p.48), double click on the desired recorded data file. “T&D Graph” will be opened and a graph displayed.

Print Graphs

1. Open recorded data from “T&D Graph”.
2. Make any desired adjustments to the window size and aspect ratio to be reflected in the printed graph.

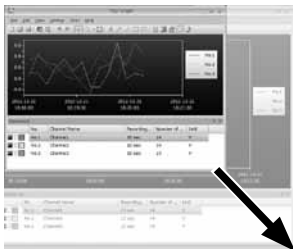

3. In the [File] menu, select [Print Graph] to view the preview image of the printed page. If necessary, go back to step **2** and change the aspect ratio again.
4. To start printing, select [Print].

“T&D Graph” also enables you to:

- Insert memos, comments, and shapes on the graph
- Merge and filter recorded data
- Copy graphs
- Display data as a list
- Export the graph as text data (in CSV format)

* Refer to Help in “T&D Graph” for details about operations and procedures.

Troubleshooting

Q1. The computer does not seem to recognize the MCR-4V, why not?

A1. Please check the following:

Check the MCR-4V

Check the USB connection between the computer and the MCR-4V.

Check the Computer

- Make sure that the software has been installed properly and is working.
- The USB driver installation may not have been installed correctly. Please see [Help for Unit Recognition Failure] in the Help menu, and check the USB driver.
- Connect a different USB device (mouse, digital camera, etc...) other than the MCR-4V to your computer and see if it operates properly.
- If your computer has more than one USB port, try connecting the USB cable to a different port.
- If you have access to another computer, try seeing if communication works with the other computer.

If after checking and trying the above there is no improvement please contact the distributor where the product was purchased.

Q2. The first reading of recorded data is invalid data, why?

A2. One of two scenarios is possible:

- When recording average values, the first recorded value is invalid because an average cannot be calculated.
- When the Preheat function has been set to ON (recording method: instantaneous values only) and the preheat time is set to longer than the waiting time before recording start, the first data reading will be invalid because preheating has not been completed.

Q3. Is it possible to change the batteries while the unit is in operation?

A3. If the unit is connected to an AC adaptor or some other external power source, it is possible to change the batteries. If only batteries are being used as the power source, it is necessary to stop recording before changing the batteries.

Q4. Is it possible to adjust or alter recorded data that has been downloaded by the MCR-4V?

A4. In order to maintain the integrity and trustworthiness of the recorded data, the software has been designed to not allow modifications to be carried out on actual recorded data. If it is necessary to edit recorded data, in "T&D Graph" save the data to text file and use a common spreadsheet software such as Excel to edit the text file data.

Q5. I get a "Write Error" when I try to export recorded data to an SD memory card, what should I do?

A5. Please check the following:

- Make sure the write protection switch on the SD memory card is unlocked.
- Check if your SD memory card is supported by the MCR-4V. (See p.38)
- Perform a "Memory Card Test". (See p.44)
- Perform a "Quick Format" for your SD card. (See p.44)

If after checking and trying the above you still get an error message, please contact the distributor where the product was purchased.

Q6. The software MCR for Windows does not start, why not?

A6. Please check the following:

- The software may not have been installed correctly. Try reinstalling MCR for Windows.
- Check to see if the software was installed with Administrator rights.

(For Windows 7 or earlier:)

- The .NET Framework 4 Client Profile may not have been installed correctly. Follow the steps below to see if the .NET Framework 4 Client Profile has been installed correctly.

In the Control Panel, open [Program and Features] or [Uninstall a Program].

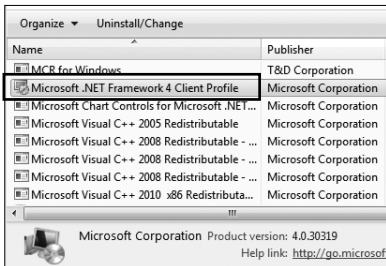

When the .Net Framework 4 Client Profile is not in the list above:

Try reinstalling MCR for Windows. The .Net Framework 4 Client Profile will be automatically installed with MCR for Windows.

When the .Net Framework 4 Client Profile is in the list above:

Follow the steps below to repair the .Net Framework 4 Client Profile.

1. Select Microsoft .NET Framework 4 Client Profile and click [Uninstall or Change].
2. In the maintenance box, select "Repair .NET Framework 4 Client Profile to its original state" and then click [Next]. Click [Finish] when prompt.

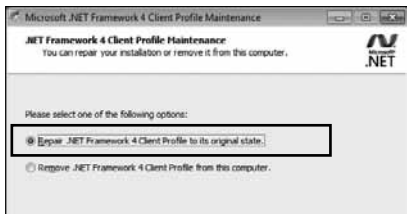

If after checking and trying the above there is no improvement please contact the distributor where the product was purchased.

Specifications

MCR-4V

Measurement Channels	Voltage 4ch
Input Method	Scanning Method, Differential Input, Each Channel Isolated
Input Impedance	Approx. 1.1 M Ω
Input Frequency	DC-100 Hz
Measurement Range	± 300 mV, ± 1.5 V, ± 6 V, ± 24 V, Auto (*1) Absolute Maximum Input Voltage: ± 50 V
Accuracy	When the 50-60 Hz filter is ON, varies with the Measurement Range as follows: ± 300 mV : $\pm(0.3\% + 0.06$ mV) ± 1.5 V : $\pm(0.3\% + 0.3$ mV) ± 6 V : $\pm(0.3\% + 0.6$ mV) ± 24 V : $\pm(0.3\% + 2.4$ mV) Auto : According to the range in use
Measurement Resolution	50-60 Hz Filter ON : 0.01 mV 50-60 Hz Filter OFF : 0.1 mV
Preheat Function	Allowable Voltage Range : 3 to 24 V (external power supply) Allowable Maximum Current : 1.0 A
Recording Method	Instantaneous, Average, or Ave. Fine
Recording Interval	2, 5, 10, 20, 50, 100, 200, 500 ms. 1, 2, 5, 10, 15, 20, 30 sec. 1, 2, 5, 10, 15, 20, 30, 60 min. (The minimum interval will depend on the number of channels, measurement range, and 50-60 Hz filter setting.)
Logging Capacity (*2)	When recording 1 channel : up to 480,000 readings/ch When recording 2 channels : up to 240,000 readings/ch When recording 3 channels : up to 160,000 readings/ch When recording 4 channels : up to 120,000 readings/ch
Recording Mode	Endless (Overwrite oldest data in the current recording session when capacity is full) or One Time (Stop recording when capacity is full)
Recording Start Method	Immediate Start or Programmed Start (by individual logger or by group)
Recording Stop Trigger	ON or OFF

Group Recording	Up to 4 units (16 channels) can be recorded simultaneously. (Coupling of MCR-4V and MCR-4TC is possible. (*3))
Communication Interfaces	USB Communication
Communication Time	Download Times for Full Data via USB - While recording (at recording interval of 2 ms.) : Approx. 3 minutes 30 seconds - With recording stopped: Approx. 1 minute 30 seconds - From a slave unit: Approx. 4 minutes 30 seconds
External Memory	SD Memory Card, SDHC Memory Card (*4) (For Manual or Automatic Data Export)
Power	AA Alkaline Battery x 2, AA Ni-MH Battery x 2, AC Adaptor AD-05A2 or AD-05C2, USB Bus Power 5V 250mA
Battery Life (*5)	Approx. 4.5 to 130 days - 4 channels, Instantaneous value recording - With AA alkaline batteries
Input Terminal / Preheat Terminal	Screwless Terminals <Compatible Wires> Single Wire : $\varnothing 0.32$ to $\varnothing 0.65$ mm (AWG 28 - 22) Twisted Wire : 0.08 to 0.32 mm ² (AWG 28 - 22), $\varnothing 0.12$ mm or more in diameter Stripping Length : 9 to 10 mm
Isolation	CH1, CH2, CH3, CH4, USB, and Preheat are isolated. (Battery terminals are not isolated from the CH1-CH4 input terminals.) CH1-CH4 Maximum Applied Voltage : ± 50 V Electrical Isolation Resistance : 50 M Ω or more (DC ± 250 V)
Dimensions	H 120 mm x W 75 mm x D 32 mm
Weight	Approx. 140 g
Operating Environment	Temperature: 0 to 50 °C Humidity: 90 %RH or less (no condensation)

*1: When "Auto" is selected, measurement range will be automatically changed according to the voltage being measured.

*2: If the logging capacity is not filled at the end of one recording session, the logger can record up to 30 times.

*3: Group Recording may not be started depending on the recording or measurement interval specifications of the connected Master unit.

*4: Please check the T&D Website for information on memory cards whose operation has been confirmed.

*5: Battery life varies depending upon the measurement interval and 50-60 Hz filter setting. All estimates are based on operations carried out with a new battery and are in no way a guarantee of actual battery life.

Software (MCR for Windows)

Compatible OS (*1)	Microsoft Windows 10 32 / 64 bit Microsoft Windows 8 32 / 64 bit Microsoft Windows 7 32 / 64 bit
Display Languages (*2)	English
Other	The Microsoft .NET Framework 4 is required.

*1: For installation, it is necessary to have Administrator (Computer Administrator) rights.

*2: We recommend using an operating system in the same language as the display language. Operation in different languages is not guaranteed.

The specifications listed above are subject to change without notice.

Option

AC Adaptor AD-05A2 / AD-05C2

USB Mini-B Type

Input : AC100 to 240V

Output : DC5V,1A

Frequency : 50/60Hz

Cable Length : 1.5m

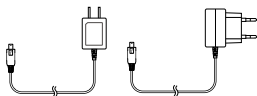

AD-05A2

AD-05C2

Plug Type



Product Support

For support, please contact the distributor from which you purchased the product.

A list of distributors can be found at:

<http://www.tandd.com/purchasing/>

Product Information

Product information can be found at:

<https://www.tandd.com/product/>

Multichannel Voltage Recorder MCR-4V

User's Manual

T&D CORPORATION

817-1 Shimadachi, Matsumoto, Nagano 390-0852, Japan

Website : <http://www.tandd.com/>

FAX : +81-263-40-3152 E-mail : support@tandd.com

Provisions for Free Repair

1. If the unit does not work properly despite the fact that the customer used it properly and in line with the manual, the unit shall be repaired free of charge through the distributor which sold the unit.
2. If the customer requests free repair because of trouble within the warranty period, bring or send the unit along with the warranty to the distributor.
3. If you have moved after purchasing, or there are difficulties contacting the distributor from which you purchased the unit, please contact T&D directly for service.
4. Free repair is not available in the following cases even though it is within the warranty period:
 1. Trouble or damage was caused by careless operation, natural disaster, fire, public pollution, or use of a power source other than specified.
 2. If repair, adjustment, disassembly or modification of the unit has been carried out by a person other than a T&D authorized engineer.
 3. Trouble or damage was caused by transportation, movement or dropping of the unit after purchase.
 4. Failure to submit the warranty or failure to fill in all items required in the warranty.
5. The warranty cannot be reissued.

This warranty only promises customers free repair within the period and conditions clarified in this warranty. Therefore, the customer's legal rights will not be limited by this warranty. For further information on repair and other service questions after the termination of the warranty period, contact your distributor.